



Historic Preservation Guidelines

Updated 2024



TABLE OF CONTENTS

I. INTRODUCTION	7
Historic Preservation Commission	7
Preservation Principles/Design Guidelines.....	7
II. CERTIFICATE OF APPROPRIATENESS PROCESS	11-15
CERTIFICATE OF APPROPRIATENESS APPLICATION	12
III. BRIEF HISTORY & MAPS, HISTORIC DISTRICTS & LOCAL LANDMARKS	19-34
IV. SECRETARY OF INTERIOR STANDARDS FOR REHABILITATION	37
V. LOCAL GUIDELINES	
Environment and Site	
Introduction	41
Paving.....	42
Garden Structures/Decks and Patios.....	43
Retaining Walls	44
Fences	44-45
Exterior Lighting.....	46
Existing Building	
Exterior Building Features	47-54
Roofs	55-57
Skylights and Roof Accessories.....	57-58
Gutters and Downspouts.....	59-60
Windows and Doors	61-67
Porches	68-72
Mechanical, Satellite and Solar	
Mechanical Equipment	73-74
Satellite Dishes	75
Accessory Structures	
Out Buildings	76
Garages	77-80
Additions to Historic Buildings	81-83
New Construction	84-87
Storefronts.....	88-90
Signs	91-93
Accessibility	94
Relocation	95
Demolition	99
VI. HISTORIC PRESERVATION AND SUSTAINABILITY	100-101
VII. APPENDICES A-F	104-127

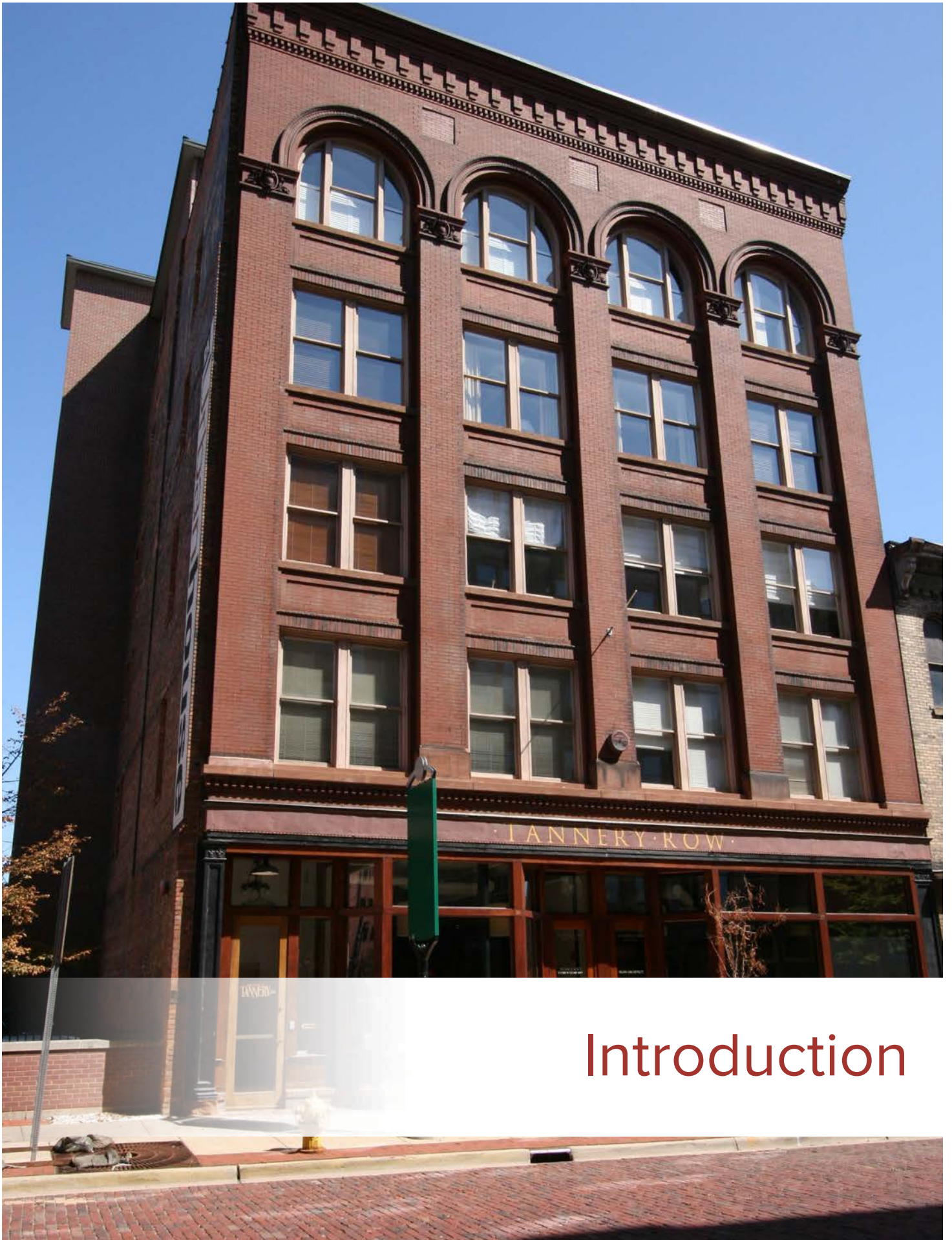

Introduction

PREFACE

All work that affects the exterior of a historic or non-historic resource or a site located within a historic district or a designated local landmark will require a Certificate of Appropriateness/Historic District Work Permit unless specifically noted otherwise in the guidelines.

The existence of other historically inconsistent work in the area is not a basis for approval of another inconsistent feature. Such inconsistent work often predates the district or has special circumstances.

Throughout the guidelines the following acronyms will be used:

- HPC** Historic Preservation Commission
- HP staff** Historic Preservation staff
- CoA** Certificate of Appropriateness/
Historic District Work Permit

As required by State Legislation PA 169 - A CoA cannot be issued unless the applicant certifies in the application (a check box exists on page 2 of the application) that the property where the work will be undertaken has, or will have before the proposed project completion date, a fire alarm system or smoke alarm complying with the requirements of the Stille-DeRossett-Hale single state construction code act, 1972 PA 230, MCL 125.1501 to 125.1531. Definitions of systems is located in the Appendix F.

INTRODUCTION

Historic Districts can be multi-resource areas such as Heritage Hill or a single resource district (commonly referred to as a Landmark), such as the Hauser House at 151 Gold NW. A historic district is defined as a significant concentration, linkage or continuity of resources united historically or aesthetically by plan or design. The district's identity is a result of the interrelationship between individual resources that work together to create a visual sense of its history.

Local Historic Districts are historically significant resources that are protected by a Historic District Ordinance. The local unit of government appoints a Historic Preservation Commission to review work proposed for the exterior of resources and sites as well as interior work that affects the exterior, to determine if the work meets the Secretary of the Interior Standards and Guidelines for Rehabilitation. To aid in the interpretation and application of the Standards and Guidelines communities are allowed, under State Act and Local Ordinance to create Local Historic District Guidelines that conform to and follow the Secretary of Interior Standards and Guidelines. Designation

of an area is one of the few ways a community can provide legal protection for its historic resources. The legal foundation for such districts is provided by the Michigan Local Historic Districts Act, Act 169 of 1970. The Grand Rapids Local Historic District Guidelines were deemed by the State Historic Preservation Office to be compatible and conforming with Section 5.(3) of Act 169 of 1970, as amended.

PRESERVATION PRINCIPLES/ DESIGN GUIDELINES

Historic preservation guidelines are intended to provide the City of Grand Rapids Historic Preservation Commission, property owners, realtors, architects/designers, builders and the like with guidelines for rehabilitation, new construction, alteration, demolition, and repairs, which would affect the exterior of historically designated buildings, sites, objects and neighborhoods. This manual is a working document to ensure that proposed changes and repairs to the historic districts and landmarks are in keeping with their architectural and historical character and are in accordance with the Secretary of the Interior Standards and Guidelines for Rehabilitation. The manual should be referred to by property owners and professionals prior to initiation of work or the submittal of an application for a permit for work within a Grand Rapids historic district and/or landmark. Familiarity with the guidelines can help property owners and professionals formulate plans and designs that respect the character of the districts and landmarks and streamline the review process. The City's Historic Preservation Specialist (HP staff or staff to the HPC) is available to provide additional assistance to applicants to help ensure a smooth review process.

Design review guidelines can have a positive economic effect on communities:

- Enhance and Protect Property Values.
- Promote Heritage and Tourism.
- Reinforce Community Identity and Marketability.
- Protect and Encourage Investment.
- Maintain a Sense of Place/Community Character.
- Promote Quality of Life.
- Promote Growth and Development.

Historic designation affords protection of investment in historic residential and commercial neighborhoods through use of design guidelines. This increases interest in designated areas resulting in the stabilization and enhancement of property values which often spills over into adjacent neighborhoods. Design guidelines ensure that rehabilitation and new construction are compatible with the character of the neighborhood thus protecting against incompatible work which could negatively impact a property's value and owners investment, while retaining the character of the historic resources.

Design review guidelines can also:

- Provide a framework for the community to achieve their vision for retaining historic resources and character while still providing for sensitive growth and modernization.
- Provide flexible approaches to addressing particular needs of an individual property and neighborhood.
- Provide guidance on maintaining the historic character of a structure/building and that of the neighborhood.
- Reduce the potential for adverse impact resulting from inappropriate treatments of individual buildings or the district as a whole.
- Clarify preservation standards for property owners, architects, designers, contractors, realtors, engineers and the like, to enable them to make informed decisions.
- Provide a consistent basis for the HPC to make well-informed decisions regarding the appropriateness of proposed work.

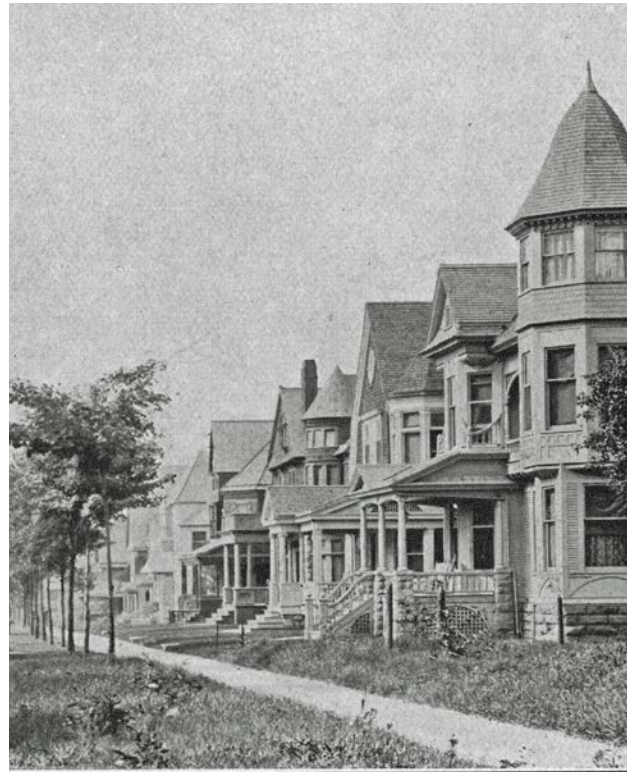

Morris Avenue





Certificate of Appropriateness Process

DESIGN REVIEW BASICS

Historic districts and landmarks require review of proposed work that affects the exterior of buildings, structures, sites, open space, and objects, before work can begin. This review is handled through a permit application process designed to preserve the architectural character and integrity of the resource(s) while attempting to meet the needs of the property owner. When a project is approved, the HPC and/or HP staff issue a work permit called a Certificate of Appropriateness (commonly referred to as either a CoA or Historic District Work permit).

The existence of other historically inconsistent work in the area is not a basis for approval of another inconsistent feature. Such inconsistent work often predates the district or has special circumstances.

APPLICABILITY

The permit application process is applicable to all properties within a designated local historic district, be it a multi-resource district or single resource (landmark), regardless of whether the property is considered a contributing historic resource or non-contributing resource. Review is required for all exterior alterations, repairs, rehabilitations, restorations, relocations, new construction, demolition and more. Review is also required for all interior work that affects the exterior. Please note that:

- Certain types of projects may require other City Permits and approvals in addition to a CoA.
- A CoA permit must be obtained before a building permit will be issued.
- Many projects that require a CoA do not necessarily require a building permit.

RESPONSIBILITY OF PROPERTY OWNER

Responsibility for complying with the historic district permit application process, CoA permit and historic district ordinance lies with the property owner. Owners and their agents are recommended to contact HP staff to discuss all projects as part of their planning phase. All applications are submitted to the HP staff who shall process each upon receipt for completeness and shall forward those completed packets requiring HPC review to the Commission's next available meeting agenda.

CERTIFICATE OF APPROPRIATENESS – HISTORIC DISTRICT WORK PERMIT

The Certificate of Appropriateness (CoA) (Historic District Work Permit) serves as the record of written approval (permit) for a proposed project within a locally designated historic district and landmark. The HPC and/or HP staff issues a CoA for the proposed appropriate work. Once issued, a CoA is valid for twelve (12) months.

There are two avenues of review for a CoA, one is HP staff review and the other is HPC review. HP staff review is granted through State Legislature PA 169 and Local Ordinance Chapter 68 stating that the HPC may delegate the issuance of a CoA for specified minor classes of work to its staff. The HPC shall provide specific written standards and a list of minor classes of work for HP Staff issued CoAs. This list is available from staff upon request, but examples are, in-kind repairs, storm doors and windows, fencing, reroofing, and documented restorations. More complex projects such as new construction, demolitions, and alterations require HPC review. HP staff reviews can typically be completed within one to two days, while HPC reviews can typically take upwards of 2 to 4 weeks as the Commission meets once a month.

CONSIDERATIONS

- Technical Infeasibility
- Economic infeasibility
- Financial hardship

PROCESS

The Certificate of Appropriateness (CoA) process is intended to provide an efficient framework by which proposed projects can be submitted to and reviewed by either the HPC or HP staff. The framework is also intended to promote consistent and fair decision-making by the HPC and HP staff in the review of proposed projects.

CoA REVIEW SPECIFICS

APPLICATION COMPLETENESS

Application submittals must be complete and include fee payment before they will be accepted.

HPC MEETING FREQUENCY/LOCATION

Once a month in room 201, 2nd Floor of 1120 Monroe Avenue NW, Grand Rapids MI



Historic Preservation Commission

APPLICATION FOR CERTIFICATE OF APPROPRIATENESS

PROPERTY ADDRESS: _____ DATE: _____

APPLICANT'S NAME: _____

APPLICANT'S MAILING ADDRESS: _____ CITY: _____ ZIP: _____

TELEPHONE # HOME/CELL: _____ WORK: _____ EMAIL: _____

PROPERTY OWNER'S NAME: _____

PROPERTY OWNER'S MAILING ADDRESS: _____

1. Describe in detail each proposed exterior alteration, improvement or repair. (Use additional paper if necessary)

What are the approximate start and finish dates of the proposed work? Start: _____ Completion: _____

APPLICATION APPROVALS EXPIRE AFTER 12 MONTHS

APPLICANT'S SIGNATURE: _____

FEES: A NOMINAL FEE DOES APPLY TO COA APPLICATION REVIEWS AND ARE DUE WITH APPLICATION. PLEASE SEE THE ATTACHED FEE SCHEDULE FOR AMOUNTS.

NOTE: Upon receipt of the application staff will determine if the submittal is complete and if it can be Staff reviewed or if it needs Historic Preservation Commission review (for a predetermination please contact staff). All work must be completed with good workmanship, meeting construction industry standards. By signing and submitting this form the applicant is granting permission for City Staff and Commissioners to enter the subject property. Should the applicant be someone other than the property owner they must include written permission to act/apply on behalf of the owner.

FOR APPLICATIONS REQUIRING REVIEW BY THE HISTORIC PRESERVATION COMMISSION PLEASE NOTE THAT ATTENDANCE AT THE COMMISSION MEETING IS STRONGLY RECOMMENDED, SEE ATTACHED INSTRUCTIONS. The Commission meets once a month in the 2nd Floor Conference Room at 1120 Monroe Ave NW at 5:00P.M. The applicant may contact staff at (616) 456-3451 or rbaker@grcity.us for assistance in completing this application.

Please contact staff upon completion of approved work for final inspection.

OVER

STEP 1.

The CoA review process should begin with careful planning using the design guidelines, which will make the review process go more smoothly and can help save time and money. In addition, having an understanding of the property and its character-defining features will also help create a project with less potential impacts to the character of the resource and environment.

STEP 2.

Contact HP staff, as they serve as the applicant's contact during the process and are available to assist in all stages of the review process including pre-planning and review of application packets prior to formal submittal. Staff will provide insight and advice as it pertains to submitted documentation as well as what may or may not be appropriate per the guidelines. Staff will also determine whether a request will require HPC review or HP staff review.

STEP 3.

Complete the CoA/Historic District Permit application form and submit along with relevant documentation, supporting material, and fee. A copy of the CoA application form is available on the Grand Rapids City Planning Department website as well as at the HP staff office. Applicants may request a form via email, mail or in person. The application is utilized for all levels of work with the exception of demolition and new construction which have a separate application form. A completed application packet should provide the HPC and/or HP staff with a thorough understanding of the proposed project. Specific submittal requirements depend on the nature of the proposed project but can generally include photographs, sketches, plans, written descriptions, and product information.

For applications requiring HPC review the applicant must submit the completed and signed form, fee and all supporting materials together to the HP staff. Packets cannot be accepted unless they are complete, for recommendations related to what material to submit see the application packet and/or contact HP Staff. Packets will be submitted by the meeting filing deadline, which is located in the back of the application form as well as on line. Please note that meeting agendas can, and often do, fill up prior to filing deadlines and as such, submittal by the deadline does not ensure placement on the associated meeting agenda. Complete applications that are filed by the deadline but received after an agenda is full will be placed on the next available agenda. For information on a specific meeting contact the HP staff. Applications that only require review by HP staff can be submitted at any time.

STEP 4.

Applications reviewed by HP staff will be examined typically within 1 to 2 business days of receiving a completed packet. If the project is found to be compatible with the Historic District Guidelines and Secretary of the Interior Standards, HP staff will issue a CoA.

STEP 5.

Applications to be reviewed by the HPC will be examined by HP staff to ensure that they are complete before accepting them. Insufficient application packets will not be accepted. (Note that an accepted application packet does not ensure that additional information will not be requested by the HPC.) Completed packets will be placed on the next available HPC meeting agenda. As part of the HPC meeting preparation HP staff will create a report outlining the project requested, the pertinent guidelines and standards, and any questions or notes. The report and the completed application packet will be placed into an E-Packet for the HPC Commissioners. These packets, along with meeting agenda and past meeting minutes, are available to the public on the City's Meeting Portal, at <http://grandrapidscitymi.iqm2.com/citizens>. Automatic emails are sent to applicants, concerned citizens, and organizations once the E-Packet is available for viewing. While the applicant's attendance at the HPC meeting is not required, it is strongly encouraged as it provides the opportunity for the applicant to present the project to the HPC, to address any questions or concerns, or to agree to any conditions of approval.

STEP 6.

All accepted applications referred to the HPC will be reviewed in a public hearing during a regularly scheduled meeting. During the meeting HP staff gives a brief presentation of the application to the HPC, after which the applicant is afforded the opportunity to give a presentation and address any questions or concerns. This is followed by public comment from individuals in attendance and written comments provided before the meeting. Following all comments and presentations the HPC will discuss the project, apply the guidelines and standards, and vote on a motion to either: approve the CoA as submitted; or with conditions, approve via a Notice to Proceed, table the application (often for additional information); or deny the application.

STEP 7.

Outcome:

- **Approval** - Application is approved as requested with no changes. A CoA will be issued.
- **Conditional Approval** - The HPC may require changes to portions of the request to bring it into compliance with the guidelines and standards, or they may approve portions of the application but deny other portions. A CoA will be issued for the approved items that clearly denotes any required changes. A letter of Denial will be issued for all denied requests which will outline what is denied and the appeal process.
- **Notice to Proceed** - the HPC may approve a project utilizing a Notice to Proceed if any of the following conditions prevail and if the proposed work can be demonstrated by a finding of the HPC to be necessary to substantially improve or correct any of the following conditions:
 - The resource constitutes a hazard to the safety of the public or to the structure's occupants.
 - The resource is a deterrent to a major improvement project of substantial benefit to community and the applicant proposing the work has obtained all necessary planning and zoning approvals, financing, and environmental clearances.
 - Retaining the resource will cause undue financial hardship to the owner when governmental action, an act of God, or other events beyond the owner's control create the hardship, and all feasible alternatives to eliminate the financial hardship, which may include offering the resource for sale at its fair market value or moving the resource to a vacant site within the historic district have been attempted and exhausted by the owner.
 - Retaining the resource is not in the interest of the majority of the community.
- **Table** - The HPC may table an application if it determines that it does not have enough information about the project to either approve or deny, or if the applicant would like additional time to provide a solution to a potential issue the HPC has raised.
- **Denial** - The HPC shall deny an application if

it determines that the project does not meet the Local Historic District Guidelines and Secretary of Interior Standards and Guidelines for Rehabilitation. In these instances, a new application for the same proposal cannot be submitted for a period of one (1) year from the date of denial, lest the HPC allows otherwise in their motion. New applications that are substantially different than the denied project can be submitted at any time. The HPC shall issue a denial letter that outlines the denial and appeal process.

Options if Denied:

- The applicant can elect to not move forward with the project, unless it is required to correct a violation of City Code Chapter 68 or other City Code violation at which point the owner will need to significantly modify the request and re-apply.
- The applicant can modify the proposed project and application to bring it into alignment with the guidelines and standards, and submit the amended project to HP staff for new review. If the request requires HPC review may only return to the HPC in less than one (1) years time, if the request is substantially different than that which was denied.
- The applicant can, within 60 days of the denial, appeal the finding of the HPC to the State Historic Preservation Review Board in Lansing, Michigan.

Step 8.

Once a CoA is issued for a project, the applicant can apply for any building permits or other necessary City approvals. A copy of the CoA should be included with those submittals.

Step 9.

Once all approvals are in place the project may begin. Should the applicant determine that a change in the scope of the project is necessary or that the project will extend past the CoA's date of validity, the applicant must notify HP staff as soon as possible to determine if a new review is required to avoid any violations. Please note that if work begins it must be completed in a manner compliant with the approval and cannot remain partially finished.

- All approvals and decisions are made based on the character and integrity of the individual property and its historical context/environment. No decision is, nor should it be construed as, precedent setting.

WORK DONE WITHOUT A CoA

For properties located within a historic district or landmark any exterior or interior projects, that affect the exterior that is begun without a CoA, will constitute a violation of City Ordinance Chapter 68. A Stop Work Order, a Correction Notice, or a Complaint Notice will be issued. Potential outcomes include:

- The property owner will complete and submit a CoA application form requesting to retain the work as is or with modifications if necessary to be in alignment with the guidelines and standards. If the completed work and any continued work meets the standards and guidelines it will be reviewed by HP staff or when necessary the HPC. If approved, the violation will convert to a CoA permit. Or;
- The property owner applies to retain and/or continue work that does not appear to meet the guidelines and Standards and/or the requested work falls outside the purview of HP staff. In such instances the request will require review by the HPC. The HPC may approve in part or in whole, may require changes, and/or may deny and require restoration. Or;
- The owner fails to obtain a CoA, and fails to bring the work/resource into compliance. This constitutes a violation of City Ordinance Chapter 68 and owners will face fees and a potential misdemeanor complaint.
- Owners that begin work under a CoA but either do not finish the work or fail to comply with the conditions of the CoA are in violation of Chapter 68. Owners in violation will face fees and potential misdemeanor - as outlined in the Grand Rapids City Code Chapter 68.

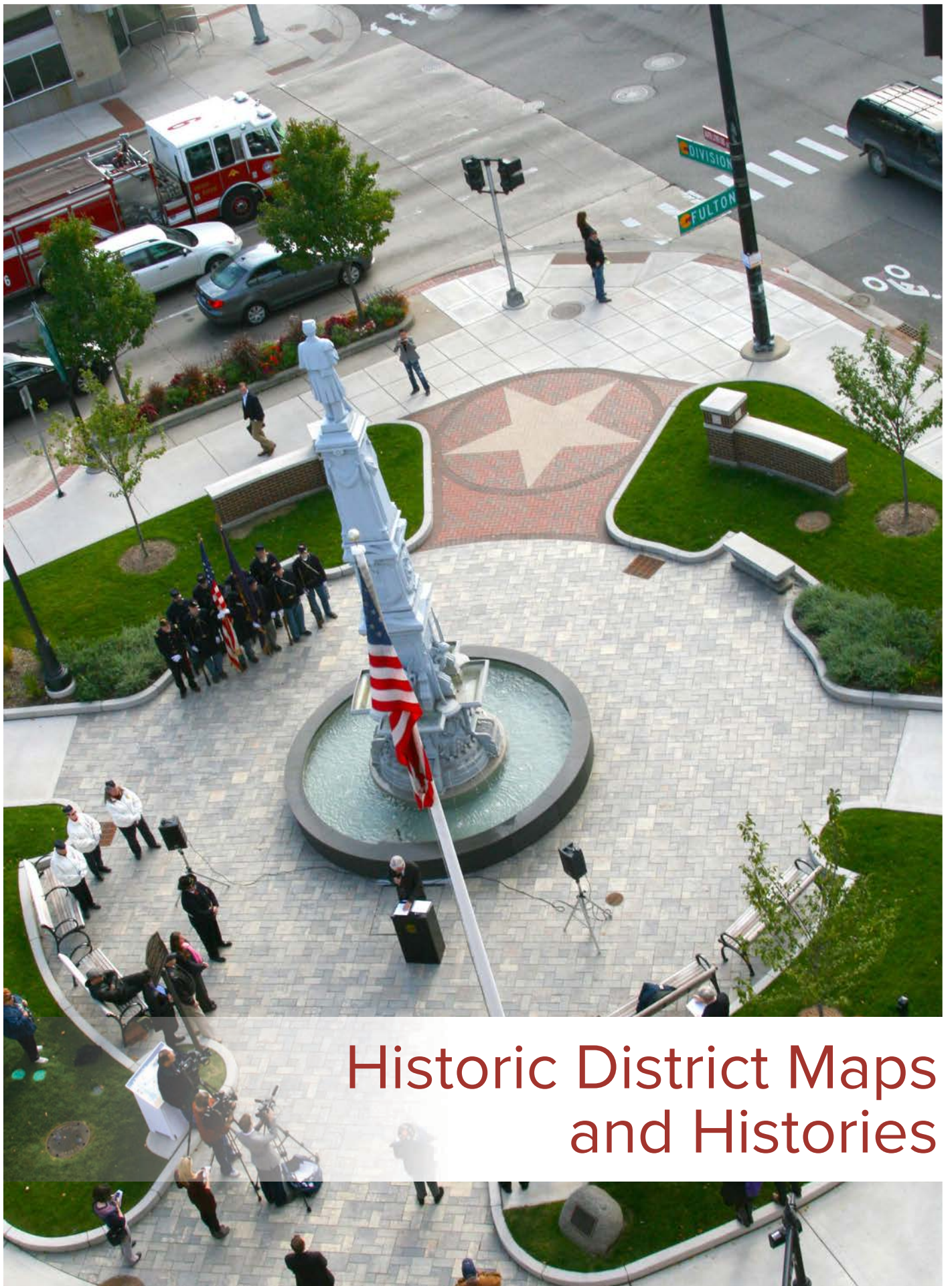

Historic District Maps and Histories

HISTORIC DISTRICTS

Grand Rapids Historic Districts may be monumental or simple, residential or commercial, with multiple resources or a single resource. A historic district is a legacy, linking present and future generations with their heritage and providing diversity vital to a city's future quality of life.

Since 1973, Grand Rapids has designated six multi-resource historic districts and 79 local historic landmarks. Ledyard Block, Heartside, Heritage Hill, Cherry Hill, Fairmount Square, Wealthy Theatre, Berkey and Gay, American Seating and the Sixth Street Bridge are a few examples.

HERITAGE HILL HISTORIC DISTRICT

The Heritage Hill Historic District is the oldest district in Grand Rapids and one of the largest historic districts in the nation. The area was designated in 1973 as a reaction to the loss of many significant and publicly loved historic structures in Grand Rapids.

HISTORY

Grand Rapids, incorporated in 1838 and quickly prospered due to its lumber and furniture businesses. As early as 1845 the population growth was creating a need for more housing.

Grand Rapids' industrial leaders saw the potential in Heritage Hill for residential development and rapidly began constructing large manor houses there. By 1920, the once rural farmland had been converted into an up-scale residential neighborhood. Early residents of the area included lumber barons, industrial leaders, banking executives, downtown merchants, doctors and lawyers. A few of the notable residents were Harry C. Leonard, refrigeration manufacturer; the Gay Family, furniture manufacturing; Herpolsheimers, retail and wholesale; the Gilbert Family, gas company; Samuel Fuller, banker; the Morris Family, steamboat services, and Jacob Steketee, attorney.

Heritage Hill thrived as an economically exclusive neighborhood through the 1930s. By the 1940s, a large portion of the original owners had passed away or moved. Their estates were divided into apartments as the need for housing increased after World War II, however, the neighborhood did not begin to truly suffer until the 1960s. Deterioration began as a result of suburbanization and urban flight. In reaction to this exodus, many cities developed urban renewal plans that focused on removing the deteriorated historic buildings and erecting new structures. The Hill suffered greatly as a result of these processes. Public outcry in the 1970s at the loss and degradation of the historic neighborhoods led to the introduction of historic preservation in Grand Rapids. In fact, a Heritage Hill resident,



College Avenue



Heritage Hill marker

John Logie, drafted the state enabling law (PA 169) to protect Michigan's historic resources.

Due to the efforts of local citizens, the protection afforded by the historic designation of the district, and new theories on urban renewal, Heritage Hill has nearly come full circle. Although many of its larger houses will never return to single family use, the district is once again a premier residential neighborhood.



Historic Areas - Heritage Hill (North) Grand Rapids, MI

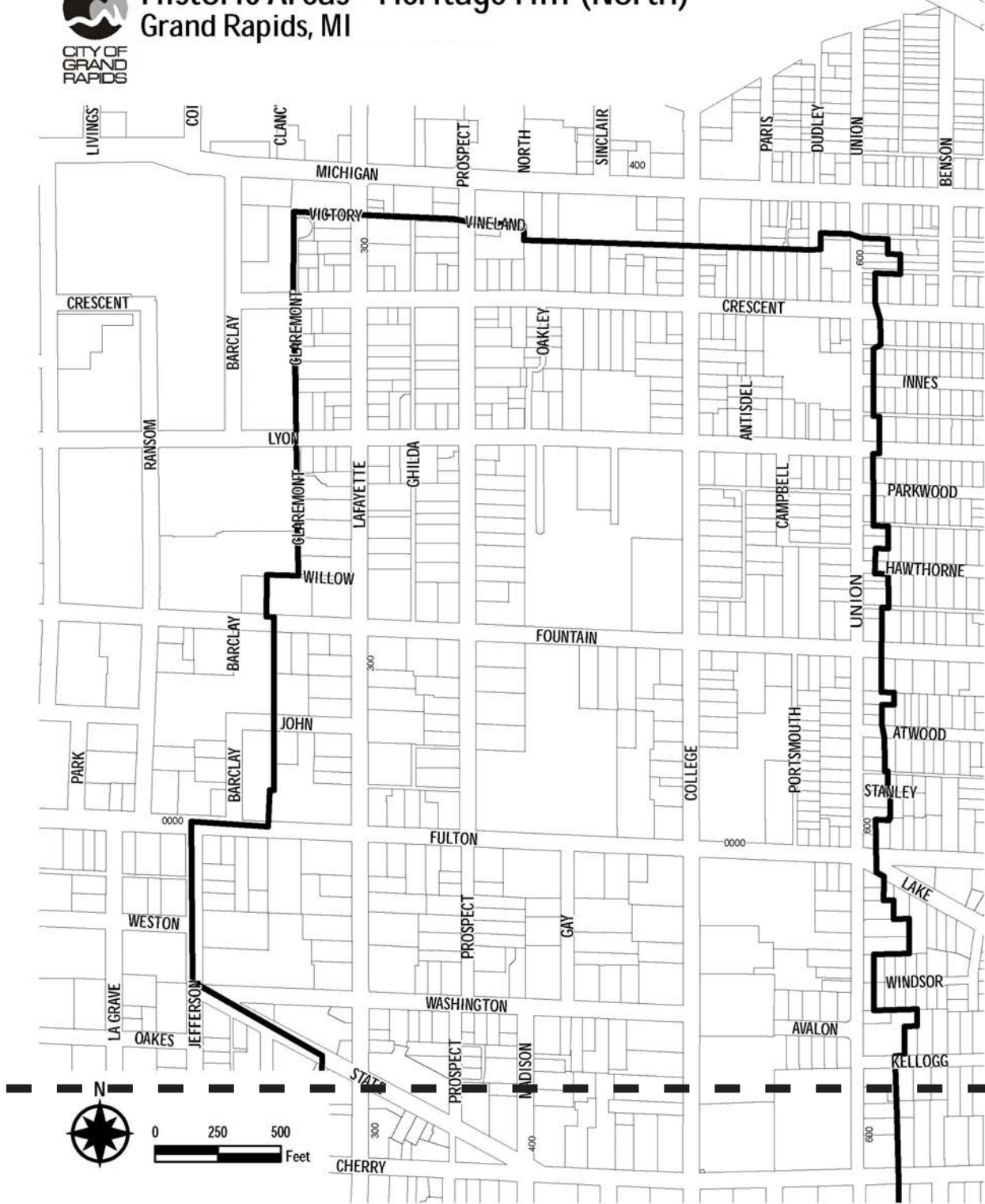



Historic Areas - Heritage Hill (South) Grand Rapids, MI

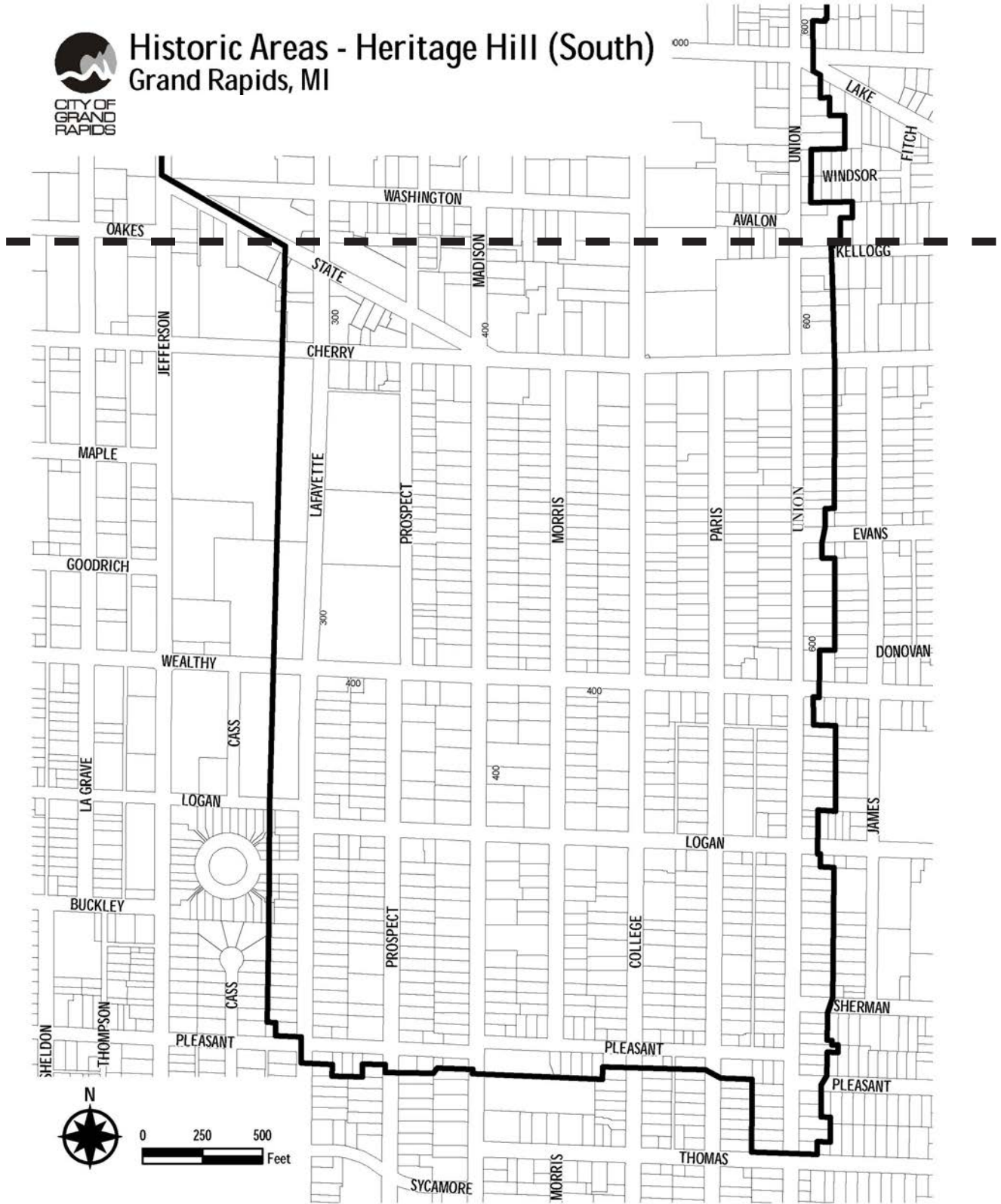

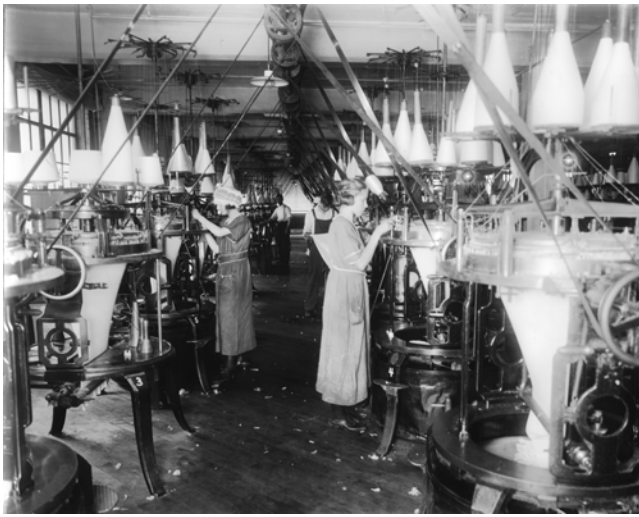

Widdicomb and Richards Furniture Factory - 1870



Globe Knitting Company

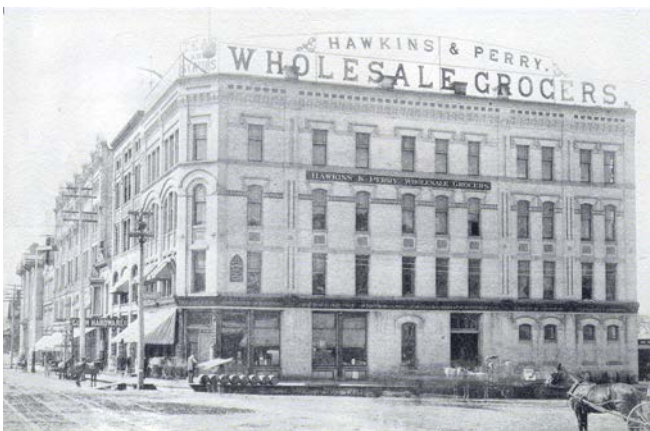

South Ionia Street

HEARTSIDE HISTORIC DISTRICT

The Heartside Historic District was first designated in 1979, in an effort to protect the remaining historic structures and to bolster economic development of the neighborhood. The boundaries of this district were expanded in 1984, 1999 and again in 2003.

HISTORY

The Village of Grand Rapids grew steadily from its inception in 1838, as a result of various manufacturing operations that developed as off-shoots of the lumber industry. The most prominent of which were boat builders and furniture manufacturers. These industries used steamboats to transport goods to outside markets until 1850 when the railroad was brought to Grand Rapids. By 1890, trains were running on six roads in ten different directions, providing access to markets in Chicago and throughout the East. This new form of transportation enabled furniture manufacturers to enter the 1876 Philadelphia Exposition where they won national acclaim. By 1900 Grand Rapids was promoted as the “Furniture Capital of the World.”

The Heartside District developed as a direct result of its proximity to the railroad and railway stations, which made it a prime location for loading facilities and wholesale houses. Henry Heystek, owner of the Heystek & Canfield Company, a wholesaler of wallpaper and paint, became one of the areas earliest investors when he purchased the first lot on Commerce Street in 1906. Mr. Heystek’s promotion of the area led to the erection of the National Candy Company factory at 40 Cherry Street SW. Other renowned companies soon followed such as the Globe Knitting Works, founded by Eiler Clement, inventor of fitted underwear, and the A.F. Burch Company, an upholstery materials and furniture supply company.

The Heartside District continued to prosper into the early 1960s, when circumstances such as, the natural expansion of businesses outside of the area, the advent of the trucking industry replacing railroad use, and urban disinvestment led to its decline.

Within the past 20 years the Heartside Historic District has experienced a rebirth due to the combined efforts of private investors, local government, and historic preservation.



Historic Areas - Heartside Grand Rapids, MI

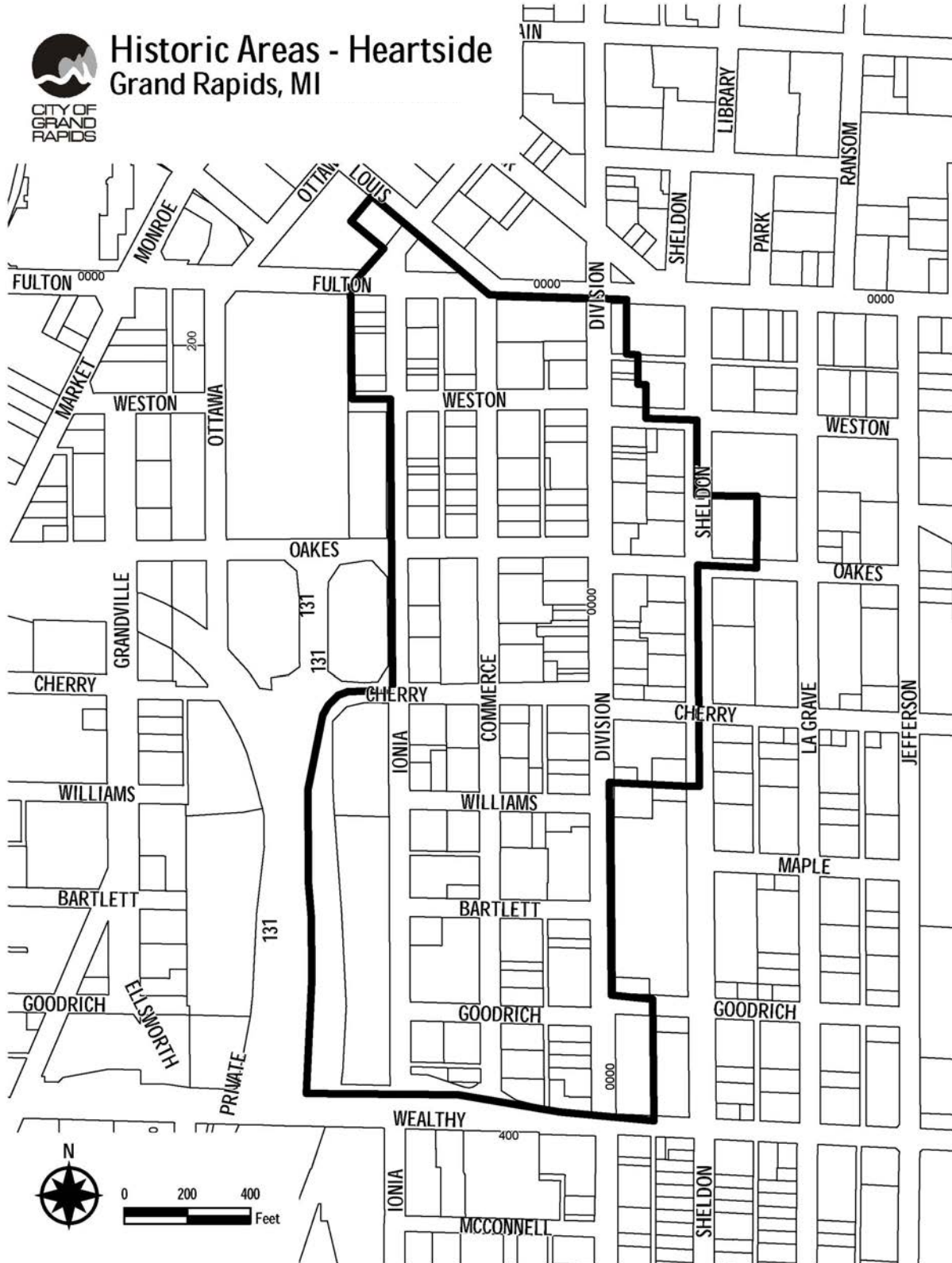



225 Henry, 1946



341 Charles, 1946

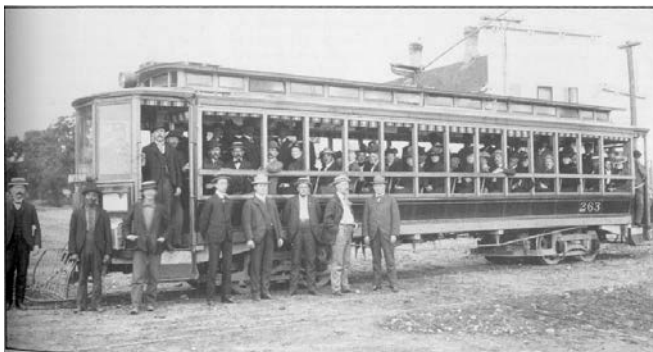

Electric Street Car, 1891

CHERRY HILL HISTORIC DISTRICT

The Cherry Hill Historic District was a model revitalization project, undertaken by residents determined to save their neighborhood. By 1991 one-quarter (25%) of Cherry Hills' homes were vacant and falling into disrepair. Many structures were being lost to vandalism and fires. As a method to combat the decline citizens came together and nominated the area for historic designation in 1994. As a result of designation and the hard work of citizens the neighborhood has completely turned around and is once again a highly sought after place to live.

HISTORY

Grand Rapids doubled in population between 1840 and 1890, causing a housing shortage. In 1875, a horse drawn streetcar line was installed on Wealthy Street to provide the necessary transportation for the development of land east of Heritage Hill, known today as Cherry Hill.

Cherry Hill became home to the city's growing middle class. Some of the early residents included builders, salesmen, millers, railroad workers, bankers, attorneys, grocers, clerks and teachers. Even though the builders used pattern books and balloon-frame construction method, each homeowner added their own style, which resulted in no two homes being exactly alike.

In 1914 electric streetcars were installed on Cherry and Wealthy Streets, providing more efficient transportation for residents of Cherry Hill, which led to an explosion of businesses in the district. Consumers could select from wares offered at neighborhood meat markets, hardware stores, dry good stores, grocery stores and drugstores.

As the years passed Cherry Hill suffered the same fate as Heritage Hill, homes were converted into apartments and urban flight and suburban sprawl left many structures vacant and vulnerable to vandals. Through the 2000s local efforts dramatically increased owner-occupancy, which has led to the redevelopment of the commercial properties along Wealthy and Cherry Streets. Boarded up storefronts have been restored and numerous businesses have seen the benefits of the rebirth of this historic neighborhood.



Historic Areas - Cherry Hill Grand Rapids, MI

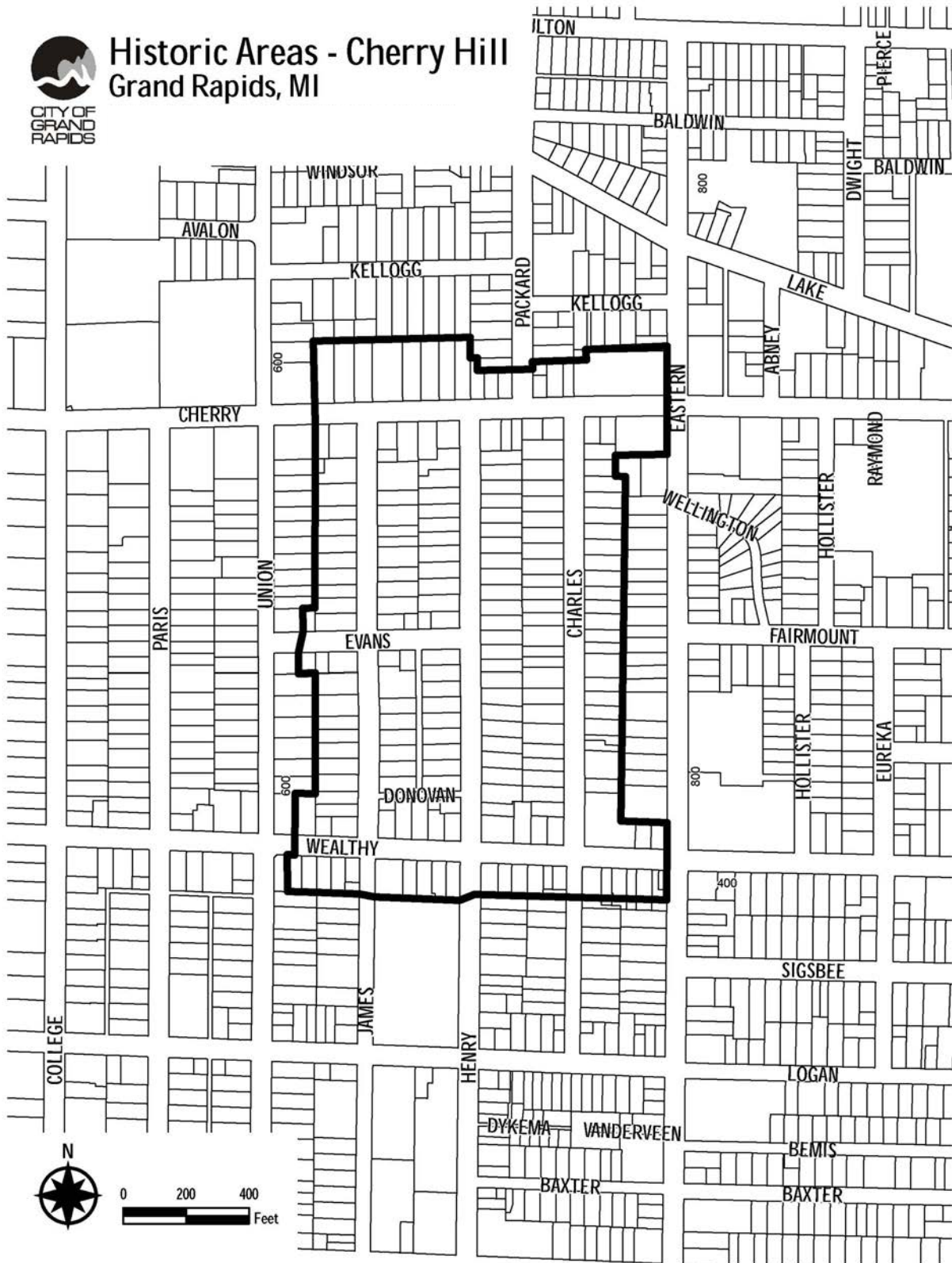



Wealthy Street Streetcar

WEALTHY STREET HISTORIC DISTRICT

The Wealthy Street Historic District was designated in 1997 to protect remaining historic structures and to aid in the economic redevelopment of this once thriving commercial corridor.

HISTORY

In 1872 business owners along Wealthy Street raised \$17,000 dollars to donate to the Grand Rapids and Reed Lake Railway as a contribution to pay for the construction of a streetcar line along Wealthy Street. The introduction of the streetcar allowed the area to fully develop by becoming a favorite stopping place for travelers on their way to and from Reeds Lake, a popular resort destination.

The residential portions of the district were developed through the removal of area farms and orchards and the construction of simple frame residences, many of which housed the area's second wave of Dutch immigrants.

The neighborhoods' location adjacent to the streetcar line and its active residents quickly made it a highly desirable place to live. This popularity became more evident in 1911 when Thomas and Laura Giles built the Pastime Vaudette (Wealthy Theatre). The construction of the theatre spawned more commercial growth, such as Freyling and Mendels Nursery (demolished) and Huizenga Hardware store (1035 Wealthy SE).



Wealthy Theatre, 1930s

The neighborhood continued to thrive until the 1970s when residents began to move to the suburbs and large chain stores pushed out the mom and pop stores. Many homes were abandoned and storefronts were boarded and left vacant. Through it all, a few loyal businesses remained. In the mid 1990s, these businesses, along with neighborhood associations, formed the South East Economic Development, Inc. (SEED). SEED was created to promote the redevelopment of the Wealthy Street commercial corridor through the rehabilitation of existing historic buildings. Through the combined efforts of local residents, businesses, SEED and historic preservation, the Wealthy Street District is once again a place of increasing opportunity and success.



Wealthy Street Floral Co., 1925



Historic Areas - Wealthy Theatre Grand Rapids, MI

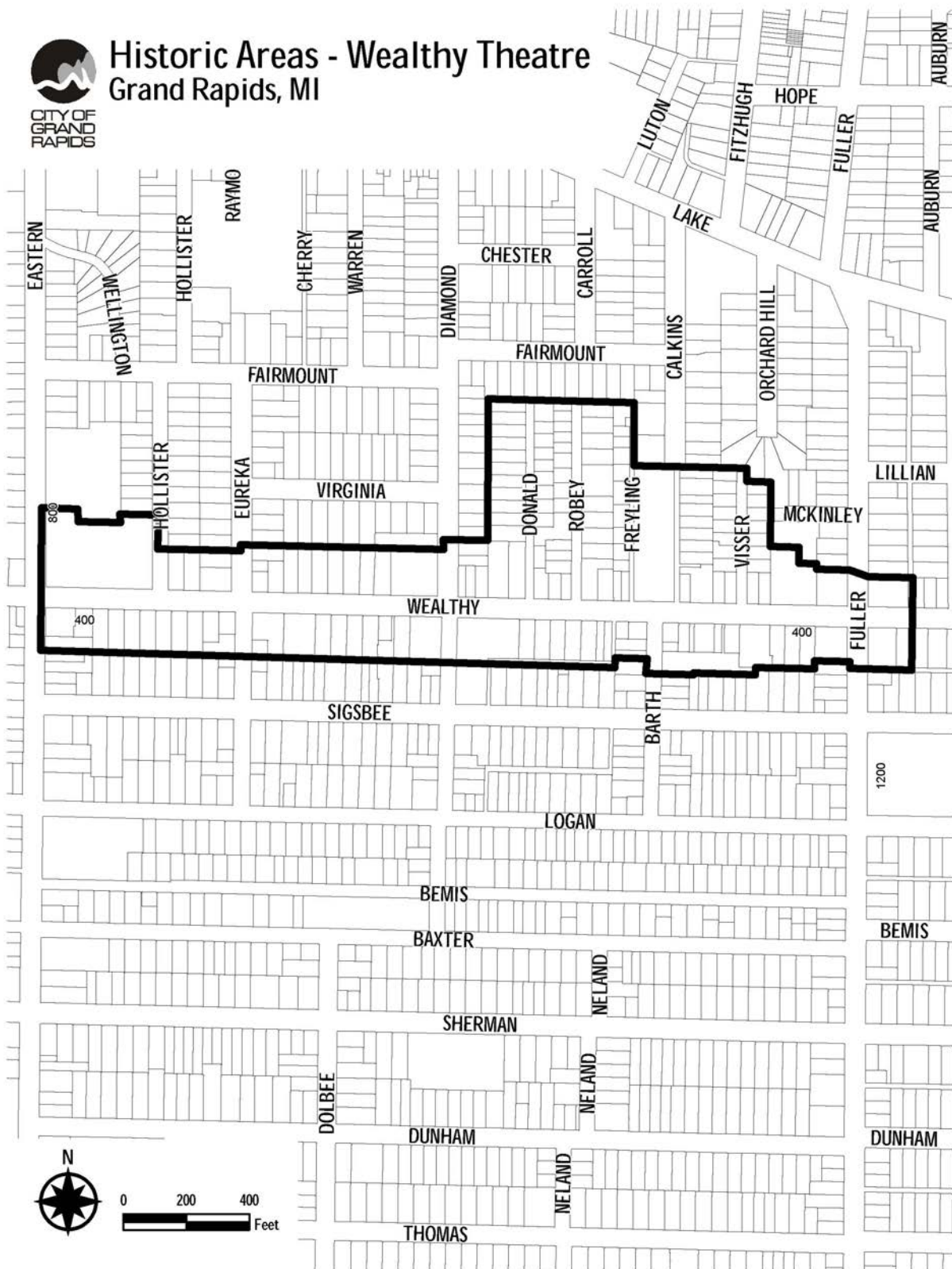



Cherry Street Streetcar



Webb Academy for Girls, 330 Eastern



327 Hollister , 1939

FAIRMOUNT SQUARE HISTORIC DISTRICT

The Fairmount Square Historic District was designated in 1999, at the request of area residents seeking to stabilize their neighborhood, protect the historic structures and promote the area's revitalization.

HISTORY

In the mid-1800s a majority of what is today known as Fairmount Square was owned by prominent local farmer, A.W. Fisher. Mr. Fisher resided in the large Italianate house at 330 Eastern SE which later became the Webb Academy for Girls and is currently home to a design firm. In 1860, Mr. Fisher sold his land for residential and commercial uses, but development of the area did not begin in earnest until the streetcar line was installed along Cherry Street in 1876.

Fairmount Square became home to many prominent citizens, such as Martin Lillie, Vice President of Old Kent Bank; Samuel Metcalf, Metcalf Funeral Homes; Julius Able, Kent County's first practicing Attorney; Edie Carroll, Constable of Grand Rapids Township; and Albert Carroll, Chief of Police for Grand Rapids.

As a result of residential growth an influx of commercial interests along Eastern Avenue and Cherry Streets developed. The most notable were: Blodgett Hospital for Children; Metcalf Funeral Home; The Half Way House, a stage coach inn, Grand Rapids Medical School and the Ebeling Black Smith shop. The area grew into a high-spirited and independent neighborhood where residents and travelers could enjoy a performance at the Half Way House or dine at one of the various restaurants and gathering places along Cherry Street.

By the 1970s the neighborhood was showing signs of decline. Houses were converted to apartments and businesses along Cherry Street either moved out or closed. This decline continued through the 1990s, until residents, with the help of area business associations and historic preservation, began to turn the neighborhood around. As a result, many of the historic homes have been restored and Cherry Street is once again a thriving commercial corridor.



Historic Areas - Fairmount Square Grand Rapids, MI

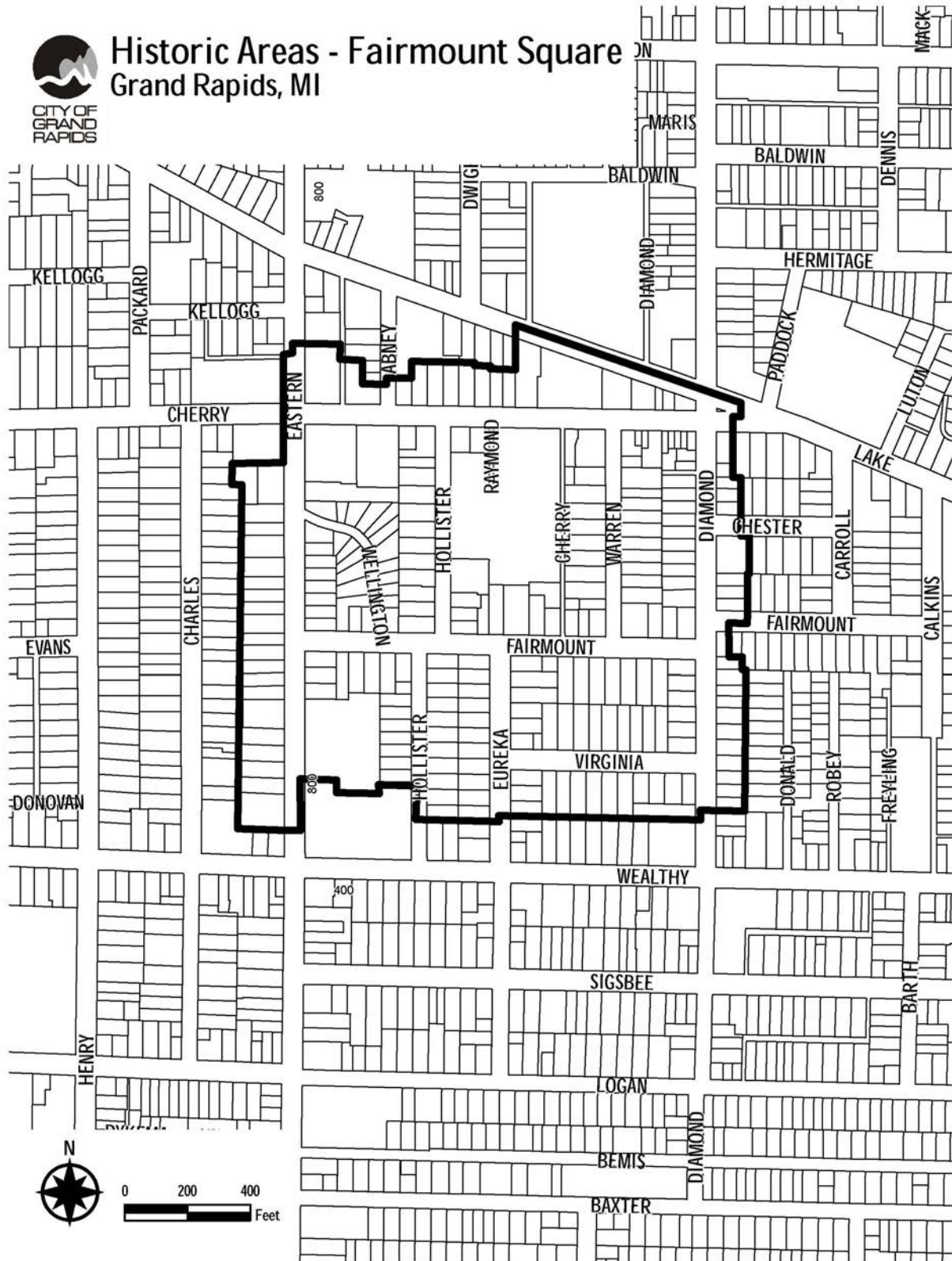



*235 State St. SE, built in 1836
The Calkins Law Office is considered to be the oldest remaining frame structure in Grand Rapids*



*6th Street Bridge, built in 1886
Longest, oldest remaining metal bridge in Michigan*

HISTORIC LANDMARKS

A Local Landmark is a single site Historic District, which can be a site, objects, buildings or structures. Most people are familiar with at least one of the five multi-resource historic districts such as Heritage Hill, but few are aware of Grand Rapids' vast array of Local Landmarks. These individually designated landmarks are just as important to the history of Grand Rapids as the historic districts.

Through the combined efforts of the Historic Preservation Commission, the City Commission and local citizens, 79 of the city's historic landmarks have been protected through historic designation. The City designated the first landmarks on April 24, 1973. They include the Norton Indian Mounds, St. Cecilia Music Hall, Abram W. Pike House and the E.H. Turner House.

Local Landmarks are not simply grand houses; they also include parks, bridges, fountains, commercial and industrial buildings, cemeteries and gravesites. Below is a sampling of the city's Historic Landmarks.



*Home to Grand Rapids Study Club from 1937 to 2002
an African American Womens literary organization encouraging appreciation of African American culture.*

HISTORIC LANDMARKS LIST (CITYWIDE)

Name	Address	Approx. Date Established	Designated
01.... Norton Indian Mounds District	2200 Indian Mounds Dr. SW	<1200	04/24/73
02.... Heritage Hill Historic District	Heritage Hill Neighborhood	1860>	04/24/73
03.... St. Cecilia Music Hall	24 Ransom Ave. NE.....	1894	04/24/73
04.... Abram W. Pike House	230 Fulton St. E.....	1845	04/24/73
05.... Eliphalet H. Turner House	731 Front Ave. NW	1846	04/24/73
06.... Ryerson Public Library	111 Library St. NE.....	1904	09/10/74
07.... Calkins Law Office	235 State St. SE.....	1836	09/10/74
08.... Voigt House	115 College Ave. SE.....	1895	09/10/74
09.... Fulton St. Cemetery	805 Fulton St. E.....	1838	09/10/74
10.... St. Andrew's Cemetery.....	900 Madison Ave. SE.....	1852	09/10/74
11.... Ledyard Building.....	145 Ottawa Ave. NW	1874	09/10/74
12.... Former Federal Building.....	148 Ionia Ave. NW.....	1909	10/21/75
13.... Trowbridge St. Cobburnlessone	200 block Lafayette to Clancy	1890	10/21/75
14.... North Ave. Cobburnlessone.....	900 block Walnut to Cedar	1890	10/21/75
15.... Cathedral of St. Andrew	267 Sheldon Blvd. SE.....	1876	10/21/75
16.... Ladies Literary Clubhouse	61 Sheldon Blvd. SE.....	1887	10/21/75
17.... Oakhill Cemetery	603 Hall St. SE	1859	10/21/75
18.... First Park Congregational Church	10 E Park Place NE.....	1868	10/21/75
19.... Veterans Memorial Park.....	101 Fulton St. E.....	1833	10/21/75
20.... Civil War Memorial (Statue).....	2 Division Ave. N.....	1885	06/28/77
21.... John Ball Memorial (Statue)	John Ball Park (Fulton & Valley)	1920	06/28/77
23.... Charles W. Garfield House	200 Burton St. SE	1860	06/28/77
24.... Charles W. Garfield Gravesite	300 Burton St. SE	1934	06/28/77
25.... Uhl-Hall House.....	512 Overbrook Lane SE.....	1912	06/28/77
26.... Maurice Shanahan House.....	1331 Carman St. NE	1880	06/28/77
27.... Seventh Day Adventist Church.....	100 Sheldon Blvd. SE.....	1894	06/28/77
28.... Fountain Street Church	24 Fountain St. NE.....	1924	07/03/79
29.... Edward L. Briggs House.....	2420 Plainfield Ave. NE.....	1852	07/03/79
30 .. Engine House No. 6.....	312 Grandville Ave. SW.....	1879	07/03/79
31.... Greenwood Cemetery.....	1340 Bristol Ave. NW.....	1860	11/27/79
32.... Moses V. Aldrich Memorial	John Ball Zoo SW (W Fulton)	1925	11/27/79
33.... Charles E. Belknap Statue.....	Belknap Park (Coldbrook St. NE)	1931	11/27/79
34.... Jacob Aman Gravesite.....	Aman Park (Ottawa County)	1926	11/27/79
35.... Campau Trading Post (Plaque)	NW corner Monroe & Pearl	1909	11/29/79
36.... Slater's Indian Mission	Ah-Nab-Awen Park	1909	11/29/79
37.... Garfield Park Lodge.....	300 Burton St. SE	1906	11/27/79
38 ... Heartside Historic District	S Division & W Fulton.....	1870>	12/04/79
39.... Holmdene (Aquinas College)	1607 Robinson Rd. SE.....	1908	02/19/80
40.... The Castle	455 Cherry St. SE	1886	02/19/80
41.... Coit Avenue School.....	617 Coit Ave. NE	1880	07/01/80
42.... Monroe Water Filtration Plant.....	1430 Monroe Ave. NW.....	1912	07/01/80
43.... Rapistan Schoolhouse.....	1755 Michigan St. NE	1911	07/01/80
44 ... Grand Rapids Study Clubhouse.....	427 James Ave. SE.....	1874	07/01/80
45.... Engine House No.9.....	27 Leonard St. NW.....	1890	07/01/80
46.... James O. Fitch House.....	39 Fitch Pl. SE	1856	07/01/80
47.... Calumet Flats Building.....	301 Division Ave. S.....	1907	12/02/80
48.... Karl-Aldrich Building	98 Monroe Ctr. NW	1869	02/03/81
49.... Third Reformed Church	1009 Hermitage St. SE.....	1895	02/03/81
50.... Flat Iron Building.....	102 Monroe Ctr. NW.....	1860	07/07/81
51.... Flat Iron Commercial Block	112-124 Monroe Ctr. NW	1860	07/07/81
52.... Charles C. Comstock House	151 Boltwood St. NE	1890	03/30/82

HISTORIC LANDMARKS LIST (CITYWIDE) CONTINUED

Name	Address	Approx. Date Established	Designated
53.... Augustus Paddock House	1033 Lake Dr. SE.....	1896	07/20/82
54.... George W. Welsh Auditorium.....	200 Lyon Square NW	1932	05/28/85
55.... Meyer May House	450 Madison Ave. SE.....	1909	11/18/86
56.... Villa Maria	1315 Walker Ave. NW.....	1904	06/16/87
57 ... Louis Campau Gravesite.....	St. Andrew's Cemetery	1871	04/24/90
58.... Hebe Fountain	3000 Monroe Ave. NW.....	1893	11/20/90
59.... Gerald R. Ford Boyhood Home.....	649 Union Ave. SE	1910	11/20/90
60.... La Grande Vitesse Sculpture	301 Ottawa Ave. NW	1969	01/08/91
61.... GR Indiana RR Bridge	Downtown Riverfront.....	1892	01/08/91
62.... Boulevard House	951 Cherry St. SE	1874	11/05/91
63.... Sixth Street Bridge.....	200 block Newberry St. NW.....	1886	09/29/92
64.... Wealthy Theatre	1130 Wealthy St. SE	1911	05/24/94
65.... Cherry Hill Historic District	East Hills Neighborhood.....	1870>	06/07/94
66.... Charles A. Hauser House.....	151 Gold Ave. NW	1892	11/20/96
67.... Wealthy Theatre Historic District.....	Wealthy St. (Eastern to Fuller)	1880>	11/04/97
68.... Aldrich Block	87-99 Monroe Ctr. NW.....	1874	12/02/97
69.... Peck Building	34-50 Monroe Ctr. NW.....	1875	04/28/98
70.... Fairmount Square Historic District.....	East Hills Neighborhood.....	1870>	12/09/99
71.... Berkey & Gay.....	940 Monroe Ave. NW.....	1892	08/22/00
72.... Weirich & Oroiquis.....	400-404 Bridge St. NW	1887>	09/11/01
73.... Trust Building	40 Pearl St. NW	1891	05/28/02
74.... American Seating Factory	801 Broadway NW	1888>	05/06/03
75.... Metal Office Furniture Building.....	401 Hall St. SW	2005
76.... Mathias Alten House.....	1593 East Fulton St.	1907	06/19/07
77.... Rood Building.....	139 Pearl St. NW	1873	07/26/11
78.... Centruy Furniture	40 Logan St. SW.....	09/27/11
79.... Congress School	940 Baldwin St. SE	1921	02/19/13



Historic Landmarks - Citywide Grand Rapids, MI

CITY OF
GRAND
RAPIDS

Please refer to back of sheet for a detailed
listing of landmarks by number.

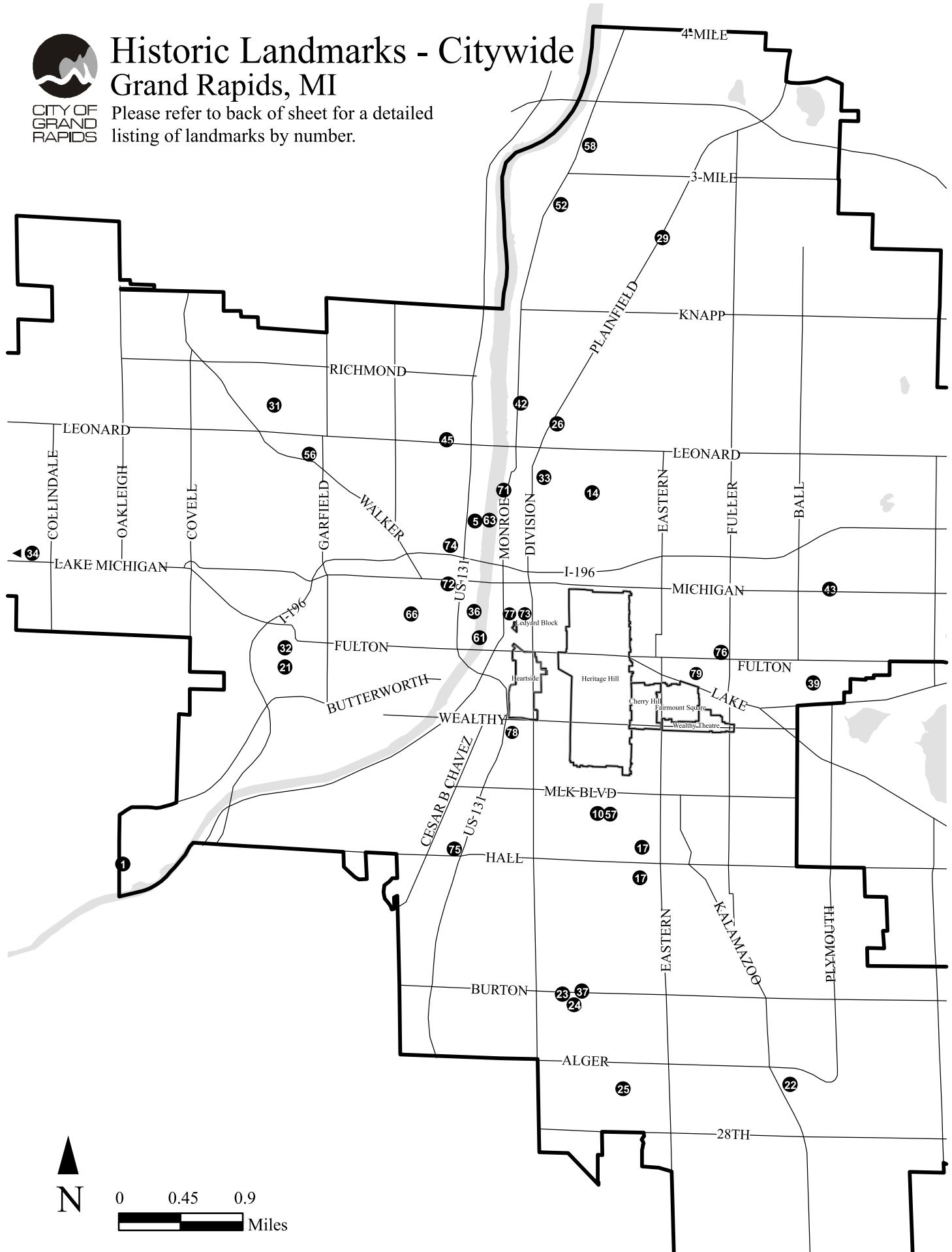

0 0.45 0.9
Miles



Historic Landmarks - Downtown Grand Rapids, MI

CITY OF GRAND RAPIDS

Please refer to back of sheet for a detailed listing of landmarks by number.

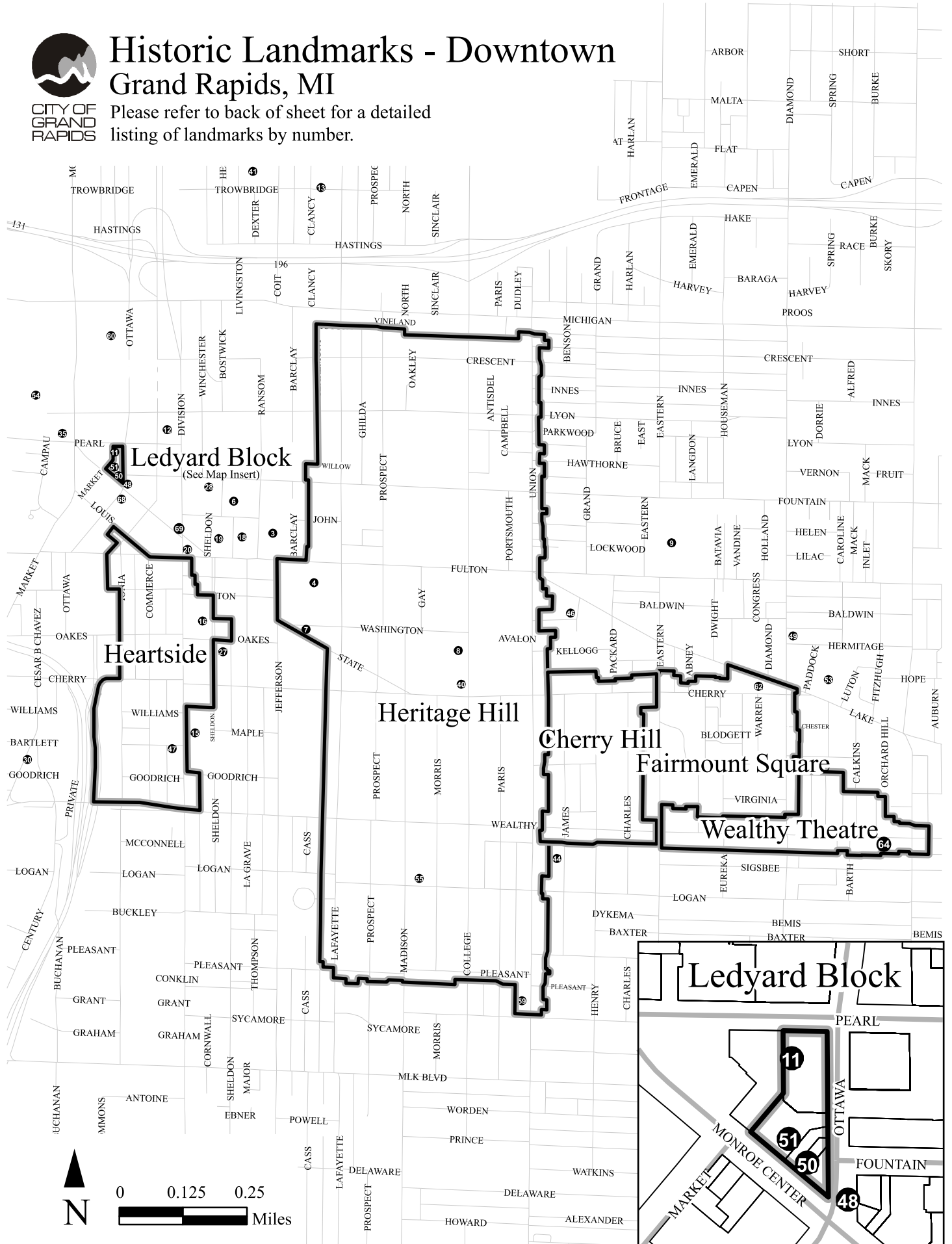

0 0.125 0.25 Miles



Secretary of Interior's Standards for Rehabilitation

SECRETARY OF INTERIOR'S STANDARDS FOR REHABILITATION

The Standards listed below were established in 1977 and amended in 1990 as part of Department of the Interior regulations (36 CFR Part 67, Historic Preservation Certifications). These are the national standards created by the Department of the Interior and the National Park Service to serve as the basis for local communities across the country. The Rehabilitation Standards acknowledge the need to alter or add to a historic building to meet continuing or new uses while retaining the buildings historic character. They pertain to historic resources of all materials, construction types, sizes, and occupancy. The Standards also include related landscape features, site and environments as well as attached, adjacent, or related new features.

1. A property will be used for its historic purpose or be placed in a new use that requires minimal change to the defining characteristics of the building and its site and environment.
2. The historic character of a property will be retained and preserved. The removal of historic materials or alteration of features and spaces that characterize a property will be avoided.
3. Each property will be recognized as a physical record of its time, place, and use. Changes that create a false sense of historical development, such as adding conjectural features or architectural elements from other buildings, will not be undertaken.
4. Most properties change over time; those changes that have acquired historic significance in their own right will be retained and preserved.
5. Distinctive features, finishes, and construction techniques or examples of craftsmanship that characterize a property will be preserved.
6. Deteriorated historic features will be repaired rather than replaced. Where the severity of deterioration requires replacement of a distinctive feature, the new feature will match the old in design, color, texture, and other visual qualities and, where possible, materials. Replacement of missing features will be substantiated by documentary, physical, or pictorial evidence.
7. Chemical or physical treatments, such as sandblasting, that cause damage to historic materials will not be used. The surface cleaning of structures, if appropriate, will be undertaken using the gentlest means possible.
8. Significant archeological resources affected by a project will be protected and preserved. If such resources must be disturbed, mitigation measures will be undertaken.
9. New additions, exterior alterations, or related new construction will not destroy historic materials that characterize the property. The new work will be differentiated from the old and will be compatible with the massing, size, scale, and architectural features to protect the historic integrity of the property and its environment.
10. New additions and adjacent or related new construction will be undertaken in such a manner that if removed in the future, the essential form and integrity of the historic property and its environment would be unimpaired.



LINKS

More information can be found on the National Park Service website here:

- [Standards and Guidelines](#)
- [Treatment of Cultural Landscapes](#)

TECHNICAL PRESERVATION BRIEFS

The National Park Service in an effort to assist historic building owners has published the "Preservation Briefs". These are a series of Technical Briefs providing information on a wide range of topics, from masonry cleaning to how to repair your historic windows. A list of the Briefs as well as locations for obtaining them can be found in Appendix A.



Environment
and Site

PREFACE

Please note that following guidelines contained in this booklet does not constitute approval, a CoA permit is still required unless otherwise indicated.

ENVIRONMENT AND SITE

Environment and site refers to elements such as greenspace, landscaping, site contours, paving, garden structures, decks, retaining walls, fences, set backs, site location, spatial relationships, yards, and exterior lighting. The guidelines for this section have been broken down into individual categories. All work requires review by HP staff or the HPC unless specifically noted otherwise. (For additional guidance and guidelines see [National Park Service Guidelines](#) for the [Treatment of Cultural Landscapes](#).)

- Retain the historic relationship between buildings, landscape features, and open spaces.
- Preserve natural landforms, as well as designed grades and contours, that are significant to the historic character of the site and/or environment.
- Preserve historic curbs, edge walls, and other features that are significant to the historic character of the site and/or the environment.
- The introduction of any new building, streetscape, or landscape feature that destroys historic site patterns or vistas or is out of scale, incompatible, or inappropriate to the setting's historic character will not be permitted.

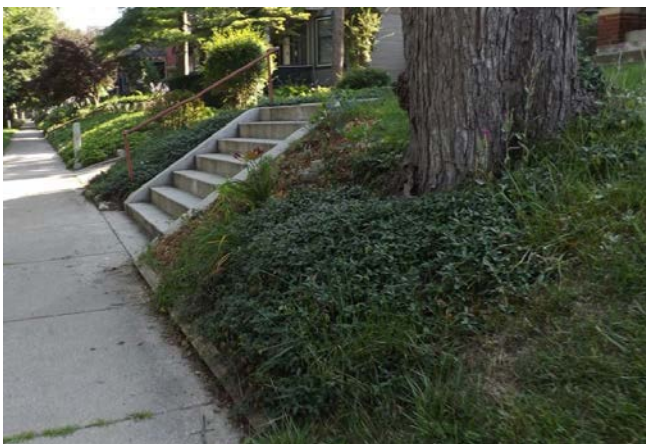

Historic land contour - raised site, grassy slope, central stairs - such features contribute to a district's historic character.

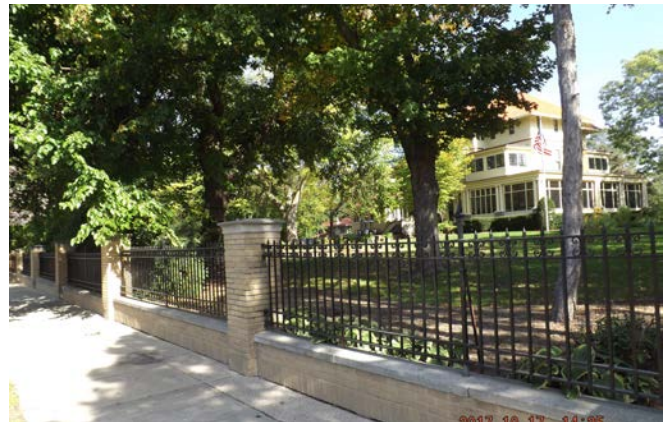

Historic site feature



Spatial relationships between main buildings, the street, and accessory buildings is a character-defining feature of a district.

PAVING

Paving refers to any structure or material that is used for walks, drives or other surfaced areas. Repair and replacement of existing paving or introduction of new paving requires review.

- Curb cuts:
 - o “Radius” and “Modified Radius” style curb cuts will be used, a diagram is available from HP staff. The “radius” curb cut is not only historically appropriate, but also provides additional space for on-street parking.
 - o Flare style curb cuts are more typical to newer developments and will only be considered if evidenced to be the historic design for the area.
- Paving will be consistent in design, material, and scale with historic features and environments. For paving, simple scored concrete, raised aggregate concrete, stone, brick or other historic materials will be used. Asphalt and other modern concrete treatments will only be considered where it has been illustrated to either be the historic material for the site and/or is the established character of the district and will not affect the visual context and historic character of the site.
- The paving of portions of a rear yard will be reviewed based on impact to site configuration, historical features, historic environment, and hard surface to grass/green ratios (the City Zoning Code standard of 40% of the lot remains “green” is a starting point for reviews).
- The paving of side yards will only be considered if it does not affect the historic streetscape, historic environment, historic character and vistas, or historic relationships of buildings and environment.
- The paving of residential front yards will not be permitted as it jeopardizes the relationship between buildings and streetscape as well as the historic environment.
- Driveways
 - o Designs may consist of solid surface or ribbon. A ribbon driveway consists of two strips of hard surfacing with green between.
 - o Materials must meet those noted above.



Approach and Driveway



Ribbon Driveway

ZONING CODE AND DRIVEWAYS

- City Zoning Code prohibits the use of crushed concrete, dirt and gravel for driveways and parking areas.
- City Zoning Code requires a minimum of 11 feet of space to install a new driveway, 10 foot width for the driveway and 1 foot buffer between driveway and lot line.
- City Zoning Code requires that a driveway must extend a minimum of 20 feet past the rear wall of the building when no garage exists. Where a garage exists the driveway must extend to that structure.
- City Zoning Code requires that residential lots in a Traditional Neighborhood maintain 40% of the lot as green. For details contact staff.
- Additional regulations for driveways exist in the City Zoning Code which can be found on the City’s Planning Department web page.

GARDEN STRUCTURES & OBJECTS

Garden structures and objects include, but are not limited to, open structures such as playhouses, gazebos, arbors, trellises, pergolas, tree houses, and objects such as fountains, sculptures and works of art. A garden structure does not require review unless it meets one or more of the following criteria:

- Attached to permanent footings.
- Has walls (open or solid) and/or a roof and is larger than 50 square feet.
- Attached to a building such as a house or garage.
- Is visible from the public right of way such as streets and sidewalks.

Please consult with HP staff to determine whether a project will require review or not.

DECKS AND PATIOS

Decks require a CoA permit. Decks as defined in this section strictly pertains to platform structures, either elevated or at grade, that are located in a rear yard. Such structures that are proposed to be located in side or front yards will be required to follow the Porch section of the Guidelines, unless determined otherwise by the HPC. Decks can be appropriate when they respect the historic character, features, design, and scale of the primary building and surrounding historic district.

- Decks and patios are to be free standing and will not attach to a historic building or structure, unless approved by the HPC
- Rails will be simple in design matching the rail design illustrated in the porch section of the guidelines, or be a design compatible with the architectural style and time period of the historic building without detracting from it or creating a false sense of historical development.
- Examples of a few, but not all inappropriate rail designs see images to the right.
- Height of decks and patios is a site sensitive issue and will be reviewed on a case by case basis, taking into account the foundation height of the main structure, the massing of the main structure, and site contours and forms, and visual impact to surrounding historic environment and district.
- When allowed by Housing and Building Codes, low lying or flush decks and patios may be built without rails.
- Floor materials will consist of masonry (stone,

brick, pavers, concrete), wood, or composite deck boards (3" to 6" wide) or tongue and groove (3" to 4" wide). Custom designs and alternate materials may be presented to the HPC for consideration. Floor boards may be parallel or perpendicular to the body of the house.

- Skirting is not required for decks but when desired, will either match the historic skirting on the main building, or the example noted in porch section, or be a custom design. Deck skirting will be wood, metal/wire or composite.
- Diamond design skirting will not be permitted unless it can be illustrated to be an historic design feature to the historic main building, or an in-kind replacement.
- Stair risers are required to be enclosed. Stairs consist of horizontal treads which are the portions one steps on and vertical risers which are the gaps between treads. Per code, risers cannot be left open but have to be enclosed with a solid piece of wood or masonry, depending on the style and material of the stair. Alternate materials may be presented to the HPC for consideration.
- Decks are exempt from the painted exterior woodwork requirement.
- Rail and Skirt materials will be selected to complement the primary historic structure and may include historical materials or alternative materials if the overall design, details, and finishes are compatible with the primary historic structure and surrounding historic district. Alternative materials shall not abut historic materials and shall require review by the HPC.



Appropriate deck rail

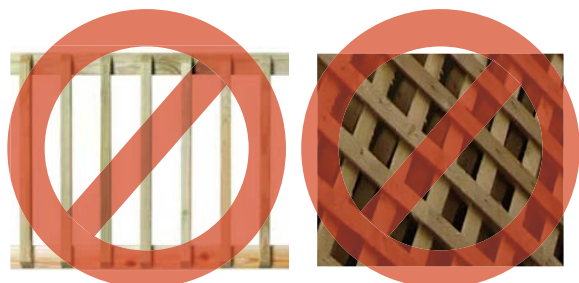

Inappropriate deck rail

Inappropriate skirt style



Modern Simple Concrete



Historic Brick



Example of a Wood, Privacy Fence

RETAINING WALLS

Retaining walls are used to retain soil or other materials, and are often found adjacent to driveways, sidewalks, walkways, and property lines. If a retaining wall presents no more than 18" of vertical exposure it does not require review; all others will require review. Any retaining wall over 4' tall also requires a Building Permit.

- Retaining walls may be considered inappropriate if they do not meet the Environment and Site section of the guidelines as it relates to natural and designed contours and features.
- Existing historic retaining walls will be retained and repaired in-kind.
- Where a historic retaining wall is too deteriorated to repair, and in-kind replacement is deemed infeasible by the HPC, a replacement wall of a simple design will be considered. The new design can not detract from the historic character of the site, environment or buildings. It may draw from the historic character of the main structure, such as the foundation or other masonry elements. Contemporary designs that add new textures, materials, or designs that are not compatible with or consistent with the historic character and features of the site, environment or building are not typically appropriate.
- New retaining walls will be consistent in design, material, and scale with historic features of the main building (typically the foundation), the building itself and the environment. Walls will reflect the historic building's foundation or be more simplistic and utilitarian in style as noted above.
- Materials will consist of either concrete(non-textured), stone, some block, landscape block, brick, or wood.

FENCES

Fencing is a barrier that defines boundaries, and/or screens, or encloses portions of a property, with or without gates. Fence materials and styles noted below are reviewed for appropriateness based on the specific associated style and era of the main structure and environment. While an iron/ornamental aluminum fence may be appropriate for a late 1800s structure it may not be appropriate for a 1920's structure.

Fences placed in the rear and sometimes side yards can often be approved by staff (an exception would be corner lots). All other fences will require HPC review.

- All new fences, including full or partial replacement of an existing fence, require a CoA as well as a City Zoning Fence Permit.

GUIDELINES

Height:

- Rear yards (from rear corner of main building back) fences up to six (6) feet in height will be considered.
- Side yards are utilized as the mediating area between rear and front. Fence heights will be considered at maximum height of six (6) feet nearest the rear and must scale down to a maximum height of three and a half (3.5) feet by the time it reaches the front wall of the body of the house (not the porch).
- Front yard fencing requires review by the HPC to determine if such a location is appropriate and compatible with the main structure as well as the surrounding historic character of the district and environment. If approved maximum height is three and a half (3.5) feet, unless otherwise approved by the HPC.
- Corner lots do not have rear yards, they have two front yards and two side yards. Any street facing façade is considered a front yard and the two non-street facing yards are side yards.
- Height measurements are taken from adjacent grade to the top of the fence panel. Height will undulate with grade.
- Distance or space between bottom of fence panels and adjacent grade shall not exceed three (3) inches.

Materials:

- Must consist of wood, wrought iron, historically appropriate masonry, galvanized double loop woven wire, or ornamental aluminum. Chain link will be considered for rear yard locations only and with a maximum height of four (4) feet.
- Zoning Code requires chain link fences be coated.
- Slats inserted into otherwise open fencing is not typically acceptable.
- Plastics, composites, synthetics and like materials typically fall short as it relates to compatibility with historic structures and environment and as such require HPC review.

Recommended:



Example of Wrought Iron ▲



Example of Wood, Picket ►

Styles:

- Although a fence style maybe noted as historic and potentially appropriate within this section all requests will be reviewed to determine the appropriateness of the requested fence style for the specific site, structure and environment that it will associate with. Example; a decorative wrought iron fence may be appropriate for a late 1800's Victorian house it would not be appropriate for a 1920's era Bungalow.
- Open vertical picket (spacing between the slats is the same width as the slat) and open vertical ornamental aluminum, or wrought iron styles of fencing will be considered for front, side and rear yard application at the above noted height restrictions.
- Solid vertical privacy style fencing, open vertical pickets, open vertical ornamental aluminum and wrought iron style fencing will be considered for side yards at the above noted height restrictions.
- Solid vertical privacy, open vertical picket, open vertical ornamental aluminum, wrought iron, or chain link styles of fencing will be considered for rear yards at the above noted height restrictions.
- Horizontal orientation requires HPC review.
- Front and side yard fences will not impede clear vision at intersections and driveways, per zoning code.
- Front yard fencing will not infringe upon or obstruct historic setbacks, vistas, streetscapes, contours, environments or neighborhood continuity. Fencing will not obstruct, obscure, damage or destroy historic buildings and/or their features or their historic site features.

FENCES CONT.

- Creating dead space or detracting from continuity of streetscapes and vistas by placing fencing arbitrarily will not be undertaken.
- Creating dead space or detracting from continuity of streetscapes and vistas by placing fencing arbitrarily will not be undertaken.

EXTERIOR LIGHTING

Exterior lighting includes, but is not limited to: wall mounted lights, ceiling lights, pole mounted lights, streetlights, and parking lot lights. Lighting will be reviewed for location, design, size, scale and any exterior wiring, conduit, boxes and the like. The Zoning Code also has requirements related to the brightness of lighting at property lines. This information can be found on the City of Grand Rapids Web Site, search Zoning Code. Most lighting requests receive HPC staff review.

GUIDELINES

- Historic light fixtures will be repaired rather than replaced.
- Historic light fixtures that are missing or beyond repair will be replaced in-kind or when not feasible, with new fixtures that are inconspicuous or that complement the style and character of the building.
- Security lighting will be designed and located discretely as to not detract from, damage, or obscure the historic building or any of its character-defining features.
- New site lighting and/or street lighting will be compatible with the human scale and the character of the historic district's environment, vistas, and streetscapes.
- Inappropriately placed fixtures that create intrusive lighting that detracts from the historic character of the site or environment will not be undertaken.
- The installation of exterior wiring and conduit that is visible along walls will be avoided, but may be considered under compelling circumstances, such as health and safety hazards when no less impactful alternative exists. At no time will such installations obscure, damage, destroy or detract from the historic character of the building and its features.



Examples of wall mounted light fixture below and a ceiling pendant above are solely included to illustrate where they are located and are not examples of appropriate styles. Styles are dependent on the style and architecture of the building.

EXTERIOR BUILDING FEATURES

WOOD

Repairs, partial replacements, whole replacements and/or changes will require a level of review by either the HP staff and or the HPC. Wood is historically the most commonly used building material. It can be found in framing, exterior cladding, and ornamental detailing. Wooden features and surfaces will be maintained and repaired to retain the historic character of the structures, objects, features, and property. Repair or replacement of deteriorated wood, may require selective in-kind replacement of only portions of a feature rather than the entire feature. It may involve the use of an epoxy wood consolidant to stabilize a deteriorated feature or it may require full in-kind replacement.

GUIDELINES

- Retain and preserve wooden features that contribute to the overall historic character of a building and site, including, but not limited to, functional and decorative elements such as siding, shingles, shakes, cornices, architraves, brackets, pediments, columns, balustrades, architectural trim, porch ceilings, floors and fascia.
- Protect and maintain wooden surfaces and features through appropriate methods. Regular maintenance such as painting and repair will occur to all wood surfaces and features.
- Repair wooden features using recognized preservation methods for patching, consolidating, splicing and reinforcing.
- If replacement of a deteriorated detail, element or feature is necessary, replace in-kind only the deteriorated portion of the detail, element or feature, rather than the entire feature. The repair and/or replacement section will match the original in design, dimensions, texture, profiles, and material.
- If replacement of an entire wooden feature is necessary, replace it in kind, matching the original design, dimension, detail, material and texture.
- If a wooden feature is completely missing or when replacing a non-contributing feature, the new feature will be based on accurate documentation of the original feature or a new design that is compatible in scale, size, finish, details, profiles, texture, and properties.
- All exposed wooden surfaces, features, details, and the like must be painted. Stripping the feature to bare wood and applying clear stain or finishes to create a natural wooden appearance will not



Wood Siding

be undertaken, with the exception of decks and porch ceilings and floors which will either be painted or stained.

- Secondary features are those that are less distinctive and less important in defining the historic character of the building, site, or environment and are often found on the rear or secondary façade with limited visibility. Replacement of secondary features need not be an exact match in materials and design if the overall historic character is still retained. The replacement shall be similar in appearance and character as to not detract from or degrade the historic integrity and character of the building, site, or environment. Should the feature about historic material the properties of the substitute material must be consistent with the historic material to avoid degradation and failure of the historic material
- Replacing wooden details, elements or surfaces with contemporary substitute materials may be considered on a case by case basis through a Notice to Proceed review when utilizing matching materials is not technically or economically feasible or an undue financial hardship or safety hazard exists as noted under Notice to Proceed, and defined by the State Historic Preservation Office in PA 169 and Local Ordinance Chapter 68.
 - Compatible substitute materials will match the historic in dimension, profiles, details, finish, textures, installation, and more.
- Introducing features or details to a historic building in an attempt to create a false historical appearance will not be undertaken.

EXAMPLE OF WOOD FEATURES



Shake & Half Timber



Brackets - Crown-Molding-Dentils



Barge Board

- Wood elements will only be cleaned or paint scrapped when absolutely necessary. In such instances the gentlest means possible will be undertaken following the Secretary of Interior Preservation Briefs for wood cleaning, see appendix A. Gentlest means possible are hand scraping and hand sanding (no power sanders), electric hot-air guns, heat plates and infra-red heating devices (being careful to not scorch the wood). Note proper lead safety laws. For details visit the Environmental Protection Agency web site.
- Cleaning or stripping wooden surfaces with methods such as blasting, power washing, planing/shaving, torching, and power sanding (such as orbital sanders) will not be utilized. Such undertakings can damage and destroy wooden surfaces and violates lead regulations.

HOW TO PRESERVE WOOD FEATURES

- Protect wood surfaces and features from deterioration by providing a protective, weather-resistant coat of paint or, in the case of shakes, colored stain. Paint all sides of any new feature in order to provide a consistent protective barrier.
- Identify, evaluate and treat the causes of wood deterioration, including faulty flashing, leaking gutters, cracks and holes in the siding, deteriorated caulking at seams, plant material, insect or fungus infestation, or leaking roofs.
- Apply chemical preservatives to historically exposed wood features such as ends of beams or rafters.
- Remove deteriorated protective coatings to the next sound layer by hand scraping and then repaint. Damaging methods such as blasting, power sanding, and power washing to remove paint will not be undertaken and can cause failure of the feature.
- When patching or splicing deteriorated wood components, use timber that matches the grain and density of existing materials.



Paint colors are not regulated in Grand Rapids Historic Districts. *The information provided here is to assist owners of historic properties who wish to enhance the appearance of their buildings through the use of appropriate paint colors. Please note that although the painting of wood surfaces does not require a CoA, the painting of masonry surfaces DOES require a CoA. Also note that the painting of masonry that is not historically painted is not typically appropriate. The painting of masonry surfaces can lead to damage of mortar and the masonry units.*

The original color of a house may be determined through paint analysis. To conduct the analysis, look for samples of the original color behind shutters or trim or in protected corners. These areas usually show the original colors because they have not been exposed to the weather and have not been scraped to bare wood. It is appropriate to assume that three or four colors may have been used in the original paint scheme of early Victorian-era houses while later revival styles (such as Tudor) may have used only a two-color scheme. White was a very common body color for revival styles while darker earth tones were often used on Craftsman styles. The paint color of trim, porch columns, doors, shutters, and wood brackets typically contrasted with the primary building color. Window sashes were often painted a darker color.

Many paint companies now manufacture colors that

replicate historic colors which can be used for reference. Most importantly, if the original color is to be painted over, leave an un-scraped patch in a protected place so a record of the original paint layers remains on the house for future owners.

Historic houses were usually painted with a lead base and later alkyd paint. This paint is generally glossier than latex paint. If a latex paint is used on the house, first install a good coat of primer manufactured to mask the old oil paint so that the new coat of latex paint will adhere properly. Failure to do so often leads to early failure of the new paint. Use a glossy finish latex paint to more closely replicate the original appearance of the house. An oil based primer with linseed oil is recommended for either new wood or where old wood has been exposed (where latex does not exist) to ensure good adherence.

(Cleaning guidelines are available in appendix A.)

SUBSTITUTE MATERIAL

The HPC does NOT endorse the re-siding or cladding of historic structures within the historic districts and landmarks. It is the policy of the Secretary of the Interior that the historic fabric of the building will be repaired or replaced in-kind when necessary. Substitute siding, trim, and claddings are not recommended as they rarely replicate the dimensions or appearance of historic materials.

Substitute material will encompass, but are not limited to, vinyls, metals, wood composites, glued particle, fiber cement, aluminum, Upson board, EIFS (Exterior Insulation Finishing System), Dryvit, Shotcrete, gunite, molded urethane, PVC (Polyvinyl Chloride), or other man-made material or man altered natural material.

- If the historic wood will not hold paint, investigate the source of the problem. If the source is not addressed, the problem will continue to cause damage to the structure even if the feature is covered or removed.
- The cladding of siding, trim or other historic features will not be undertaken as it obscures, damages and often destroys character-defining features. It also alters the proportions and relationships of all features.
- The HPC will consider requests for substitute material in cases where it is not technically or economically feasible to repair or replace the historic material in-kind. For information required for submittal of technical and economic infeasibility applications please contact HP staff.
- When matching historic materials is not technically or economically feasible (as determined by the HPC) or in instances of secondary features and new construction a substitute material may be considered, that can include synthetic as well as other natural materials. When considering substitute materials, it must match the historic in dimensions, profiles, details, color, pattern, reflectivity, finishes and textures. Where it abuts historic materials, its properties must also align with that of the historic to ensure compatible expansion and contraction and avoidance of degradation caused by incompatible materials.
- Materials such as vinyl, rough or textured wood or composites, PVC (and more) do not

adequately replicate historic wood features.

- The HPC will review all CoA applications proposing the installation of substitute material on a case by case basis. Each decision will be based on the merits of each case, no person should interpret any HPC approval for substitute material as being precedent setting

THE SIMPLE TRUTH ABOUT SUBSTITUTE SIDING

Substitute material is not a cure-all, despite what marketing materials often claim. The truth is that “maintenance free” material, are not actually maintenance free.

- Artificial claddings such as vinyl siding are considered a non-permeable material. While this means that moisture cannot penetrate the material, it also means that any moisture that gets behind the cladding will be trapped and unable dry out. As water runs along the building materials behind the siding, it will look for areas to penetrate into the building itself. No matter the careful nature of the install moisture will get in behind the siding.
- Substitute materials do deteriorate, they can dent, warp, crack, discolor, sag, fade, split, shrink and expand, and with the likes of fiber cement and Smart siding, they can absorb water and deteriorate. While timber and some masonry elements can be patched and repaired on a localized basis as needed, many substitute materials cannot be.
- Installing substitute materials can hide underlying deterioration of the structure. Simply removing the historic material and adding a substitute material will not cause the underlying issue to go away. Often it will cause the problem to worsen, and, with the problem out of sight, the deterioration will continue to occur causing untold damage to the structure.
- Substitute material can change the character of a historic building and district. Vinyl siding for example destroys the visual integrity of a historic building, it alters the scale, textures, profiles and relationships of the structure and its features.

MASONRY

Masonry encompasses a wide range of materials including but not limited to, brick, terra-cotta, limestone, granite, stucco, slate, concrete, cement block, and clay and ceramic tile.

GUIDELINES

- Protect, maintain and preserve masonry features and surfaces that contribute to the historic character of a building and site.
- Provide adequate drainage to prevent water from standing on flat, horizontal surfaces.
- Repair masonry using recognized preservation methods.
- Retain the original/historic color, finish and texture of masonry materials.
- Repoint masonry mortar joints if the mortar is cracked, crumbling, or missing. If walls are damp or damaged plaster indicate moisture penetration address the source of the moisture prior to making the repairs. Before repointing, carefully remove deteriorated mortar using hand tools. Replace the mortar with new mortar that duplicates the existing historic mortar in strength, composition, color, texture, width, and profile.
- If only a portion of a detail is deteriorated to the point of needing replacement, then that portion alone shall be removed and replaced to match the existing in design, dimensions, texture, profiles, finish, details, and material.
- If replacement of an entire contributing masonry feature is necessary, replace it in kind, matching the original design, dimensions, details, materials, finish, and texture.
- If a masonry feature is completely missing or when replacing a non-contributing feature, the new feature will be based on accurate documentation of the original feature or a new design that is compatible in scale, size, finish, details, profiles, texture, and properties to ensure physical compatibility with adjacent materials and with the historic building, site, and environment in general.
- Secondary features are those that are less distinctive and less important in defining the historic character of the building, site, or environment. Replacement of secondary features need not be an exact match in materials and design if the overall historic character is still retained. The replacement shall be similar in appearance and character as to not detract from or degrade the

EXAMPLES OF MASONRY FEATURES



Sandstone & Brick



Brick



Granite

historic integrity and character of the building, site, or environment. Should the feature about historic material the properties of the substitute material must be consistent with the historic material to avoid degradation and failure of the historic material.

- Applying paint, sealants or coatings to unpainted historic masonry is not appropriate. Such application causes damage to the historic masonry over time that is not reversible.
- The removal of protective patinas that evolve over time and are part of the building or structure's character will not be undertaken (see Cleaning for details).
- When repointing, prepare joints by using hand tools, removing ½" to 1" of old mortar to provide sufficient space to bond new mortar.

- The choice of mortar is very important in the long-term health of the building, walls, and masonry units. While lime and sand mortar are the most common and likely appropriate for repointing most historic masonry the existing historic mortar of the specific building must be tested to determine its composition as it is imperative that new mortar match the historic in its properties to ensure compatibility and to avoid degradation of the masonry units.

- The use of inflexible mortars, Portland cement, cement by itself or as part of a lime/sand mix is often incompatible with historic soft mortars. Historic soft mortars account for expansion and contraction of the masonry units and allow moisture to be expressed through the wall without damaging the masonry units. Harder mortars, Portland cements, do not allow for the expansion and contraction and trap moisture all leading to damage and loss of the masonry units. Softer mortars have long life spans, are better for the health of the building and are easily repairable and reversible allowing for retention of the historic masonry units in future repairs. Harder mortars do not allow for general maintenance, they are typically not easily reversible and often lead to the degradation and loss of historic materials.

- The HPC may consider substitute materials when use of in-kind material is found to not be technically or economically feasible (as determined by the HPC).
 - o When considering substitute materials, it must match the historic in dimensions, profiles, details, color, pattern, reflectivity, finishes and textures. Where it abuts historic materials, its properties must align with that of the historic to ensure compatible expansion and contraction and avoidance of degradation caused by incompatible materials. substitute material cannot lead to the degradation of surrounding historic materials.

- The use of synthetic caulking compounds and similar bonding agents will not be undertaken as a method of repointing.

CLEANING

The cleaning of exterior masonry for the rehabilitation or restoration of a historic building or structure is typically not appropriate as it can cause irreparable damage to the masonry. When an exterior substance, such as acidic pollutants which damage masonry or offensive graffiti



Plaster

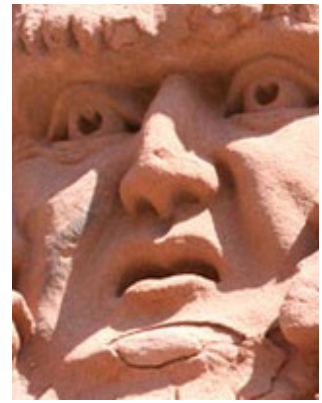

Sandstone

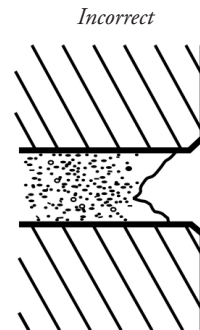

Mortar not cleaned out to a sufficient uniform depth.

Edges of brick damaged by tool or grinder. Creates a wider joint.

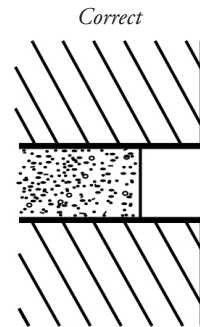

Mortar cleaned out to a uniform depth – about 1” deep.

Undamaged edges of brick.

exists removal and/or cleaning techniques can be used if they will not cause damage or permanent alteration to the historic material and features. The natural weathering and discoloration or patina of masonry materials is to be respected as the appearance achieved as a result of the original design's and selection of exterior materials. The use of any cleaning technique that removes this natural patina will be avoided. Masonry elements will only be cleaned or paint scrapped when absolutely necessary. In such instances the gentlest means possible will be undertaken following the Secretary of Interior Preservation Briefs (appendix A) for masonry cleaning as well as the Guidelines noted below.

The cleaning of any masonry surface REQUIRES review and approval by either the HP staff or the HPC through a

CoA. **Any commission approval of a cleaning technique for an individual structure should not be interpreted as allowing the unrestricted use of that cleaning technique on other materials or structures.** Each application for masonry cleaning will be reviewed and decided based on the reason for the request to undertake the cleaning, the cleaning technique proposed, and the type, age and condition of the exterior material to be cleaned.

The following are requirements for proposed masonry cleaning applications:

- An explanation of why cleaning is being proposed.
- A detailed written description of the technique to be used, including:
 - Manufacturer’s specifications as it relates to cleaning agent’s make-up, use, and application.
 - Pressure specifications are to be expressed in pounds per square inch (PSI) exerted at the nozzle of the instrument (wand).
 - If a rinse is to be used, a description of the rinse, and the pressure at which the rinse will be applied.
- An exact description of the type and location of the exterior materials to be cleaned, including their existing condition (e.g. cracked, spalling, open joints, patched, etc.)
- The HPC can require a test of product before determining if approval can be granted. The required test will be performed on a small area (9 square feet maximum), in an inconspicuous location approved by the HPC and/or HP staff. Upon completion of the test, the area will be inspected by either the HPC or HP staff to

determine if it is compliant and if a CoA can be issued.

- Approved wet cleaning (including water and chemical cleaning) will only be undertaken between April 1 and November 1 to avoid freeze and thaw issues.
- Certain chemical cleaning compositions may be permissible for certain types, conditions and strengths of brick. These same chemicals will not be permissible for other masonry materials such as stucco and stone. Stone can be stained by chemical cleaners while stucco is often too fragile in nature to sustain these chemicals. Stucco and stone are often best cleaned with mild detergents and low pressure water rinses (under 100 psi), as are most bricks.
- A water rinse, under 100 psi, is required for all chemical applications.

MASONRY SEALANTS

Applying waterproof or water repellent coatings to masonry is generally not appropriate. Not only can they alter the appearance of the masonry, sealants (breathable or not) can also prohibit the natural movement of moisture through masonry, ultimately trapping it and causing additional deterioration. Sealants are also not to be used as a substitute for appropriately repairing deteriorated materials.

APPROPRIATE

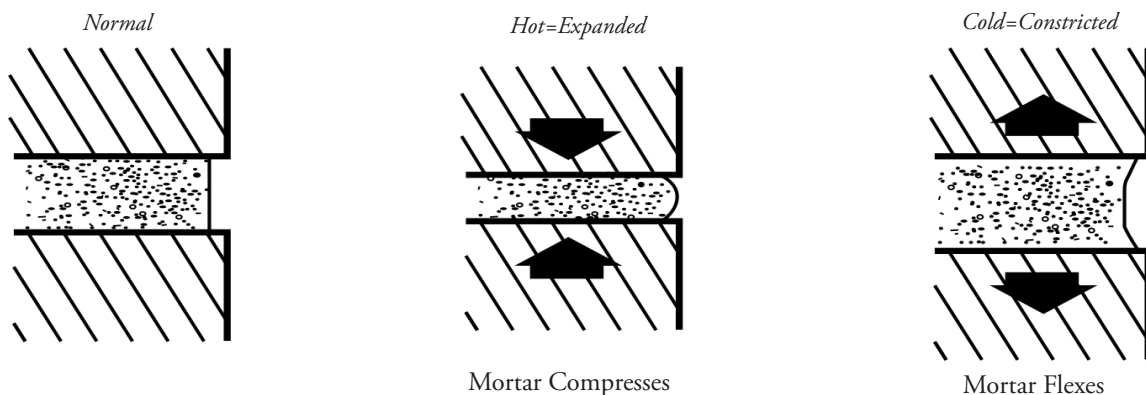

LIME-BASED, is a flexible mortar commonly found in historic homes dating pre-1920. It is very important when repointing to utilize a mortar that matches the existing in composition, as well as profile and color.

METAL

A variety of metals are employed in the detailing and surfacing of buildings, street elements and site features. Metals are commonly used for roofing, gutters and downspouts, flashing, finials, cornices, coping and cresting. Other features include, for example, storm doors and windows, vents, grates, windows, railings, and storefronts.

Metals such as copper, tin, tin-plate, iron, lead, brass, stainless steel, and aluminum are all found within historic districts. The shapes, textures, and detailing of these metals reflect the nature of their manufacture, whether wrought, cast, pressed, rolled or extruded.

GUIDELINES

- Retain and preserve metal features that contribute to the historic character of the building and site, including, but not limited to, roofing, flashing, storefronts, cornices, railings, windows and fences.
 - If a metal feature is repairable it shall be repaired rather than replaced. Repairs will use recognized preservation methods.
 - If only a portion of a detail is deteriorated to the point of needing replacement, then that portion alone shall be removed and replaced to match the existing in design, dimensions, texture, profiles, finish, details, and material.
 - If replacement of an entire contributing feature is necessary, replace it in kind, matching the original design, dimensions, details, materials, finish, and texture.
 - If a feature is completely missing or when replacing a non-contributing feature, the new feature will be based on accurate documentation of the original feature or a new design that is compatible in scale, size, finish, details, profiles, texture, and properties/physical compatibility with adjacent materials with the historic building, site, and environment.
 - Secondary features are those that are less distinctive and less important in defining the historic character of the building, site, or environment. Replacement of secondary features need not be an exact match in materials and design if the overall historic character is still retained. The replacement shall be similar in appearance and character as to not detract from or degrade the historic integrity and character of the building, site, or environment. Should the feature abut historic material the properties of the substitute material must be consistent with the historic material to avoid degradation and failure of the historic material.
- Regular maintenance of metal is critical in the prevention of corrosion and oxidation (rust), which are chemical reactions to air exposure and moisture. A sound coat of appropriate paint (one designed for the specific type of metal it is to be applied to) is key to preserving historic metal (except in the instance of copper and bronze which must retain their natural patina and cannot be painted). If corrosion begins, it will be necessary to remove all of the rust immediately followed by priming the areas with a zinc-based primer or other rust-inhibiting primer. Followed by proper replacement of the removed using recognized preservation methods.
 - Corrosion can also result from a chemical reaction caused by contact between two dissimilar metals. Patch or replace deteriorated metal in-kind to minimize the potential for unintended contact between dissimilar metals.
 - Soft metals such as lead, tin, copper, and zinc may, with approval, be cleaned using chemical methods. Blasting or other abrasive cleaning methods are prohibited.
 - Wrought and cast iron elements will be cleaned by hand scraping and wire brushing. Low pressure dry grit blasting will only be considered if it can be demonstrated that the surface of the iron will not be damaged.
 - Architectural metal features or details will not be introduced to a historic building in an attempt to create a false sense of historical development or appearance.
 - Asphalt products such as roofing tar, corrode historic metals and will not be used to patch flashing or other metal surfaces.
 - The HPC may consider substitute materials when use of in-kind material is found to not be technically or economically feasible (as determined by the HPC).
 - o When considering substitute materials, it must match the historic in dimensions, profiles, details, color, pattern, reflectivity, finishes and textures. Where it abuts historic materials, its properties must align with that of the historic to ensure compatible expansion and contraction and avoidance of degradation caused by incompatible materials. substitute material cannot lead to the degradation of surrounding historic materials

ROOFS

A building's roof form, material, and features are among its major distinguishing characteristics. Roofs help define a building's massing, volume, and presence along the streetscape. Roof forms can be flat, gable, hip, dome, pyramid, gambrel, mansard or any combination thereof. Certain architectural styles are distinguished by their roof forms: Gothic Revival displays steeply pitched complex arrangements of gables; Dutch Colonial Revival buildings are noted for having gambrel roofs (barn style). Roofs can be distinguished by any number of features, including, but not limited to chimneys, dormers, cornices, turrets, finials, cupolas, dentils, trim and eaves, which contribute to the character of the building. Roofing materials are a distinguishing feature and include standing seam metal, slate, cement or metal shingles, wood shake, clay tiles, asbestos and asphalt, to name a few. Retaining the original roof form and pitch, as well as associated features, and, where present, historic material, is important as changes to the roof can significantly alter the appearance of a building and streetscape. Review by HP staff or HPC is required.

GUIDELINES

- Maintenance is key. Keep the roof free of leaves and other debris and inspect it regularly for leaks and damage. Slate and tile are extremely durable but brittle. They can last more than a century, but their fasteners, flashing and sheathing may not. Metal roofs, if kept painted, can last more than a century as well.
- Retain and preserve roofs and their functional and decorative features that are important to the character of the building. This includes, but is not limited to, roof shape, cupolas, cresting, chimneys, cornices, weather vanes, and material.
- Repair a roof by reinforcing the historic materials and by following recognized preservation methods.
- Features missing prior to designation of the district can be recreated using physical, historical, and/or pictorial evidence to guide the work. Or a new design may be proposed that is compatible in size, scale, finish, texture, and design with the historic character of the main building.
- If only a portion of a detail is deteriorated to the point of needing replacement, then that portion alone shall be removed and replaced to match the existing in design, dimensions, texture, profiles, finish, details, and material.
- If replacement of an entire contributing feature is necessary, replace it in kind, matching the original design, dimensions, details, materials, finish, and

texture.

- Radically changing, damaging or destroying roofs will not be undertaken.
- Secondary features are those that are less distinctive and less important in defining the historic character of the building, site, or environment. Replacement of secondary features need not be an exact match in materials and design if the overall historic character is still retained. The replacement shall be similar in appearance and character as to not detract from or degrade the historic integrity and character of the building, site, or environment. Should the feature about historic material the properties of the substitute material must be consistent with the historic material to avoid degradation and failure of the historic material
- Stripping the roof of sound historic materials such as slate, clay tile, wood, or metal is not permitted.
- Changing the configuration of a roof by adding new features such as dormers, dormer windows, vents or skylights will not be undertaken unless it can be illustrated to have minimal impact on the historic character and integrity of the roof, the structure and the historic district. Consideration is given to the location, the historic material affected, scale, massing, features, proportions and more.
- Removing any historic character-defining roof feature, including chimneys and dormers, is

ROOF SHAPES



Side Gable



Pyramidal Hip

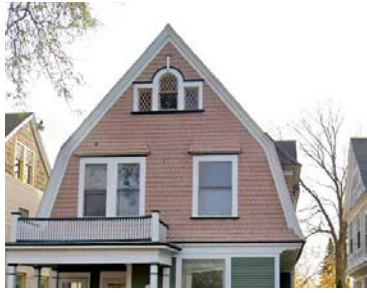

◀ *Gambrel style roof*



Mansard style roof ▼

typically not appropriate.

- Tarpaper and rolled asphalt roofing will not be installed as a finished roofing material. Roofing tar will not be installed as a replacement for valley flashing.
- Where historic roofing materials no longer exist, modern material will be considered. Such materials include asphalt shingle, metal, and other man-made materials. Each will be reviewed based on the merits of the individual case, in consideration of the buildings historical character, features, materials, scale, proportions and more.
 - o Corrugated, 5V-groove, and wide sheet metal will not be installed.
 - o If approved by the HPC and/or HP staff, standing seam metal roofing will have flat panels with widths of 8” and 12” noting the roof must have a consistent width throughout, slim standing seams and narrow corner caps. Perpendicular seams or breaks and exposed fasteners are not permitted.
- The wrapping, covering or removal of historic eaves, molding, dentils, brackets, or cornices or the like will not be undertaken.
- The HPC may consider substitute materials when use of in-kind material is found to not be technically or economically feasible (as determined by the HPC).
 - o When considering substitute materials, it must match the historic in dimensions,

profiles, details, color, pattern, reflectivity, finishes and textures. Where it abuts historic materials, its properties must align with that of the historic to ensure compatible expansion and contraction and avoidance of degradation caused by incompatible materials. substitute material cannot lead to the degradation of surrounding historic materials.

CHIMNEYS

- Character-defining and/or contributing chimneys will be retained.
- When a chimney is no longer in use, a cap can be installed if it does not diminish the historic design of the chimney, require the removal of decorative features, or damages historic materials.
- If rebuilding a chimney is necessary, existing historic material will be salvaged and reused when possible. When the historic material cannot be reused new material that matches the historic material in, scale, dimensions, texture, composition, finish, color, profiles, installation pattern, and design will be used. The design, features, and dimensions of the chimney will also be recreated. Simulated masonry materials will only be considered by the HPC when historically appropriate materials are not technically feasible.
- Reducing the height of a chimney will only be considered when necessary for safety and when it does not compromise, damage, or destroy the historic character, of the chimney.
- Lesser or secondary chimneys located, on the sides, internally, or on the rear elevation will be considered for removal if determined to be of no architectural or historical significance.

DRIP EDGE AND COPING

- Drip edges may be aluminum in material. Drip edges will not exceed 1.5” in exposed reveal so as not to cover architectural features and details.
- Where historic clay tile or other historic coping materials exist they will be carefully removed for installation of the new roofing material and then reinstalled in their historic locations and configurations. Historic coping will not be replaced with an alternate material or design, unless approved by the HPC. New coping will not be added under the historic coping unless it is not visible and does not alter appearance of historic contributing coping.

FLASHING

- All roofs will be properly flashed to meet building code and installation requirements.
- At locations where a roof meets a wall plane the flashing must go under the existing siding and trim. It cannot be installed in place of the siding and trim, nor can it be installed over top of the siding and trim, nor can trim be added in these locations to cover the flashing and bridge the gap between siding and roof plane. If siding and trim is damaged or removed to install the roof and flashing, new siding and trim must be reinstalled in the same location as the historic and in the same design, material, finish, dimensions and configuration as the historic.

VENTING

- Box or Pot Vents, the square style vents projecting through the roof plane, will be a color that blends with the roofing material and be placed to be as minimally visible as possible. Such venting requires review by HP staff.
- Ridge Vents are vents that run along roofs main ridge and can be reviewed by HP staff but require the vent to extend the full length of the ridge, end to end, to provide an uninterrupted continuous ridge.
- Wall vents, soffit vents, eave vents, and any other manner of venting, will be reviewed on the merits of each individual case. Consideration is given to location, visibility, impact to historic materials and/or features, affects to rhythms and patterns, and affects to design(s).

SKYLIGHTS & ROOF ACCESSORIES

The introduction of roof accessories such as skylights and chimneys will be reviewed based on the merits of the case to ensure that such installation does not adversely affect the historic profile, characteristics, materials or features of the roof, the building or the district requires. Review by HP staff or HPC is required.

GUIDELINES

Introducing new roof features, such as skylights, dormers, vents and solar panels will not be undertaken if it will compromise the historic character and integrity of the building or district, or the roof design, or damage character-defining features or materials.

- Installation of new roof features will not be



Sky Light

located on roof slopes prominently visible from the public right of way, thus adversely affecting the character of the roof, the structure and the surrounding environment.

- New features, such as dormers, if approved by the HPC, must be scaled to the massing of the building and other dormers present on the building.
- Skylights will be considered when located in inconspicuous locations with minimal visibility from the public right of way preferably at the rear, with no impact to historic materials and features.
- Skylights will be installed parallel to the roof plane.
- The skylight framing will be a color that blends with the roofing material.

SOLAR COLLECTORS

Solar collectors allow the property owner to reduce energy consumption by taking advantage of renewable resources. These may be either solar panels or solar shingles which translate the sun's energy into usable power. Installation of such features may be permissible and encouraged where it can be accomplished without diminishing, obscuring or damaging the historic character of the district, the site or the building and its features and materials. Solar collection systems are reviewed on a case by case basis.

ROOF MOUNTED

- Collectors will be flat with low profiles to lay parallel to the roof surface with a maximum 6" gap between outer most façade of the collector and the roof surface. Exceptions may be made

for flat roofs where a parapet blocks views of the collectors and where the collectors do not affect the historic roof plane or features.

- Collectors and their associated equipment will be located in inconspicuous locations with minimal visibility from the public right of way.
- Collectors and their associated equipment will not affect physically or visually historic character-defining materials or features. Collectors will be installed in a manner that does not cause damage to the roof structure, features or materials, nor require the alteration or removal of character-defining features or materials, nor shall it obscure contributing historic features.
- Collectors and associated equipment will be compatible with the building or structure's roof line, color, and shape.
- It must be established that the roof structure can support the weight of the added collectors and equipment.
- Size of the installation, panel arrangement, and material finish will be considered during the review as it relates to both direct physical impacts, indirect affects pertaining to the historic character of the building, site, district with special attention to historic character-defining materials, features, spacial relationships, proportions, massing, scale and finishes.
- Collectors when positioned behind features such as dormers or chimneys that do not negatively impact or infringe upon said historic features, can minimize visibility from the public right of way.
- Explore installing collectors on the roof of accessory buildings at the rear of the lot rather than on the primary building roof.
- Select collectors, frames and equipment that are similar in color to roofing materials in order to minimize their appearance.

SITE LOCATED

- Collectors and their associated equipment will be located in inconspicuous locations with minimal visibility from the public right of way.
- Collectors and their associated equipment will not physically or visually affect historic character-defining materials, features, vistas, environment or spacial relationships. Collectors shall be installed in a manner that does not cause damage to historic-contributing site features or require removal of or obscuring of character-defining



An approved Roof Mounted Solar installation located at rear



An approved Roof Mounted Solar installation located on flat roof with parapet

features, nor shall it obscure contributing historic features and spacial relationships.

- Preserve natural landforms, as well as designed grades and contours, that are significant to the historic character of the site and/or environment.
- The introduction of any new building, street-scape, or landscape feature that destroys historic site patterns or vistas or is out of scale, incompatible or inappropriate to the setting's historic character shall not be permitted.
- Visual and physical affects to the structure, site, environment and district will be taken into account. Screening it with appropriate materials may be required and/or considered.
- Retain the historic relationship between buildings, landscape features, and open spaces.

WALL MOUNTED

- Wall mounting of solar panels is not permitted as it directly and indirectly damages, destroys, obscures and changes the historical context, character, features and materials of a structure and district.



GUTTERS AND DOWNSPOUTS

Gutters and downspouts refer to systems that are built into or attached to a building or auxiliary structure, to facilitate the movement of rainwater or melting snow from roofs and away from the structure. Placement and style of gutters on a historic structure varies greatly; some structures were designed to not require gutters, while others were designed with gutter systems built into the roof structure, and some were mounted at the roof's edge. To ensure adequate function without damaging or obscuring architectural features, new systems will be designed and installed appropriately based on the needs and features of each building. CoA needed.

GUIDELINES

- Deteriorated historic features will be repaired rather than replaced. Where the severity of deterioration requires replacement of a distinctive feature, such as decorative historic gutters and scuppers, the new feature will match the old in design, color, texture and other visual qualities and where possible, material.
- The permanent removal of architectural features such as decorative character-defining gutters or scuppers, that are beyond repair or replacing such a feature with a new architectural feature that does not convey the same visual appearance will not be undertaken.
- Gutter systems must be of the appropriate size to accommodate the volume of water collected on the roof during a heavy rain. Industry standards exist that denote appropriate size of gutter as it relates to the size and pitch of the roof. The most common sizes found within historic districts

range from 4" to 6" gutters, with 4" being utilized on smaller roofs such as porches.

- Gutters will be installed with straps placed under the roof shingles when possible or when needed on top of the shingle but then made a color to blend with the shingle taking extra care to ensure penetrations are properly sealed. Methods that require penetration into historic character-defining features is prohibited.
- Gutter materials will include various types of metal including, aluminum, copper and galvanized steel.
- Historic trim and moldings, or other detailing will not be removed or covered over in order to install a gutter system.
- Plastic and vinyl will not be utilized as they do not have the strength necessary to function properly.
- The installation of an improper gutter design is not permitted as it compromises existing eaves and details as well as the success of the gutter system.

GUTTER STYLES

Built-in, "K" style, and half round gutter systems all have a presence on structures in historic districts. The review of requests for gutters systems will focus on the design, details, materials, and scale of the roof edge and eave of each individual property to ensure retention of character-defining features and long-term success and economy of the gutter system.

K Style Gutters

- The K gutter is in the shape of a "square" and was popularized from the 1901's through present day. This gutter designed to be mounted flush against a flat surface. Installation typically relies on the existence of a flat vertical fascia/trim board at the roof edge for support and direct attachment. This makes this style of gutter inappropriate for roofs with moldings, decorative features, no or minimal fascia/trim, or diagonal or cutback style roof edges as they cannot give proper support to the gutter without damage to these features or the addition of a board or trim piece that does not currently exist.
- There have been advances in the K style of gutter that allows it to be installed independent of the roof eave structure by hanging the gutter by

metal straps that are attached to the roof under the shingles. This may be considered appropriate so long as it does not obscure or damage historic character-defining features. This system is not as durable or strong as the half round when hung in such a manner and may not be able to handle the amount of water.

1/2 Round Gutters – pre-1900 to present

- Designed for roof edges with moldings and other features that prohibit direct attachment and back support.
- The 1/2 round gutter is the shape of half a circle and designed to be installed utilizing straps that are attached to the roof under the roof shingles. Consideration to placement of roof straps on the surface of the roof shingle will be considered based on special circumstances that may exist.
- This system allows underlying features, moldings and rafter ends to remain exposed.

Built-In Gutters – pre-1900 to present

- There are two types of built-in gutter systems that can be found in the historic districts; one is visible from the exterior as it is built on top of the roof surface and the other is largely out of sight as it is built within the roof and eave structures, below the roof surface. Both systems allow detailing of the roof edge to be seen.
- Many built-in systems are historic and some feature historic architectural details, such as decorative scuppers and exposed detailing above the roof surface. These character-defining features will be preserved and maintained, even if the gutter system itself is no longer functioning. It is possible, depending on the design of the individual structure to encase or enclose the internal gutter systems while maintaining and visible character-defining features.

GUTTER STYLES

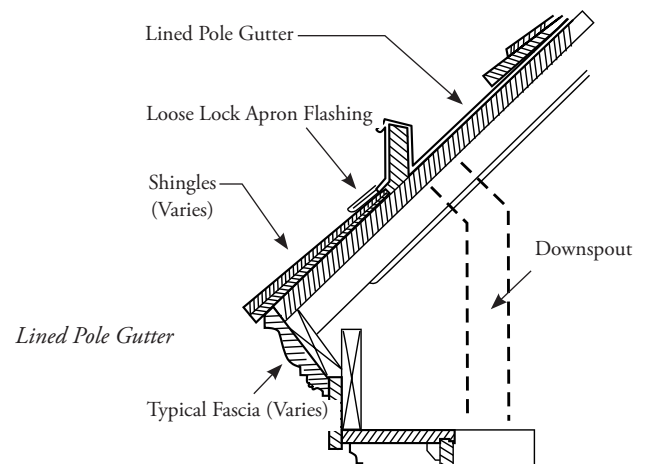
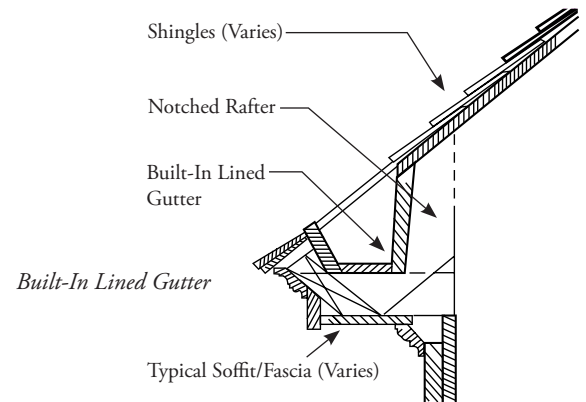
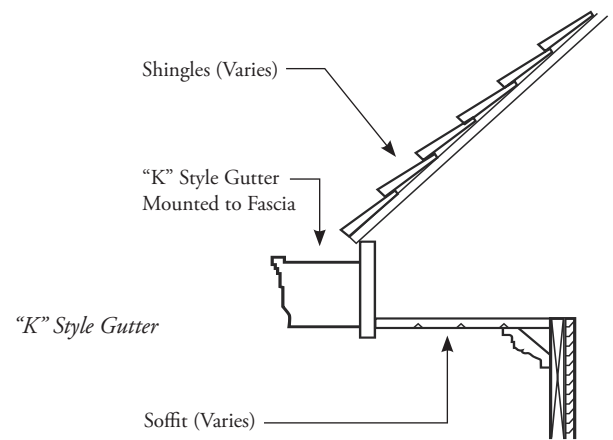
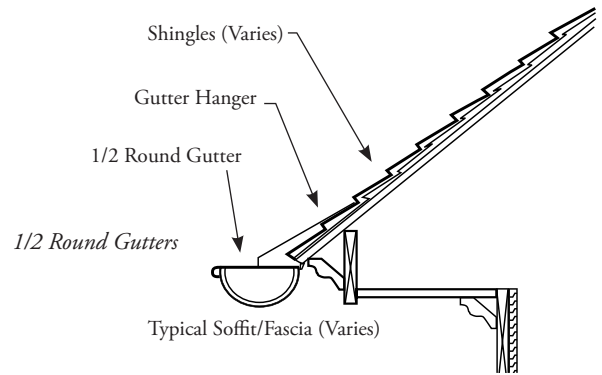

WINDOWS

The various arrangements, sizes, proportions, materials, dimensions, and features of windows are often significant character-defining features of a building and structure. Many types of windows are directly associated with specific architectural styles, such as, multi-light double-hung windows which are often found in Colonial Revival style structures, or leaded casement windows that are common to Tudor Revival style buildings.

The basic elements of a window that play a large role in their overall appearance are sashes, proportions, profiles, leading, finish, decoration, glass, material, operation, ratios, mullions, muntin's, brickmould, sills and blind stops. For example, the width and profile depth of a wood window sash and its muntin's create defined and distinctive shadow lines and visual effects. Most modern windows, such as vinyl windows, have much narrower sashes with little to no profile depth, resulting in no shadow lines and little to no definition. Likewise, muntin's placed on the interior or in between glass panes provide no definition or profile, and no real visual relief.

One of the most common misconceptions about historic windows is that they are not energy efficient. It has been proven that an appropriately weather-sealed historic window with a storm window is just as energy efficient, if not more so, than a new insulated window. In addition, historic windows of old growth wood are more stable and resistant to deterioration and, if properly maintained, can be easily repaired and last for hundreds of years. By comparison modern windows have an expected life span of 10 to 15 years and are often not repairable.

WINDOWS GUIDELINES

- Windows that contribute to the historic character of a building will be retained and preserved. This includes their functional and decorative features, such as frames, sashes, muntin's, sills, heads, moldings, surrounds, mullions, ratios, proportions, materials, profiles, finish, brickmould, blind stops, leading, glazing, and operation.
- Contributing windows and their features will be maintained through regular maintenance such as painting and glazing.
- Repair contributing windows using recognized preservation methods for patching, consolidating, splicing, and reinforcing.
- Replacement in part or in whole of a contributing window will only be considered if repair is not feasible.
- If a feature or element of a contributing window is too deteriorated to repair, then that feature/

element may be replaced but not the entire window unit. The deteriorated feature/element will be replaced in-kind matching the design, dimensions, details, and materials of the existing. Where appropriate recognized preservation methods of consolidate repair can be considered.

- If an entire contributing window unit is beyond repair and replacement is necessary, the new window unit will match existing in all facets including but not limited to; design, finish, dimensions, pane configurations, ratios, profiles, trim, sills, details, muntin's, mullions, glazing, glass, finish, location, operation, and materials. Minor deviations that do not negatively affect the historic integrity and character of the building and/or the feature, may be considered.
- When replacing a contributing window, or a non-contributing window or a missing window the new window will be sized to fit the rough opening and shall match the existing exterior trim and sill. Where the historic opening has been modified (pre district designation) the units shall be fitted to the existing rough opening or the existing opening will be restored to its historic dimension and that rough opening measurement will be utilized for the new unit. Minor deviations that do not negatively affect the historic integrity and character of the building and/or the feature, may be considered.
- Changing the dimensions of a contributing window opening will be considered for secondary facades if the change does not compromise the historic integrity of the building, cause damage to or obscure character-defining features, or cause significant loss or alteration to important ratios and symmetries.
- Secondary features are those that are less distinctive and less important in defining the historic character of the building, site, or environment. Replacement of secondary features whether that be an entire window unit, or a feature of a window need not be an exact match in materials and design if the overall historic character is still retained. The replacement shall be similar in appearance and character as to not detract from or degrade the historic integrity and character of the building, site, or environment. Should the secondary feature abut historic material the properties of the substitute material must be consistent with the historic material to avoid degradation and failure of the historic material.

- For buildings over 4 stories in height replacement of contributing windows that are too deteriorated to repair that are located above the distinctive base must match the contributing windows in size, design, and all details that can be perceived from ground level. Substitute materials may be considered to the extent that they do not compromise important visual qualities and that adequately match character defining details as noted above.
- If replacing missing or non-contributing windows the new units may replicate the existing unit, the missing historic unit or be a new design that is consistent with the general historic character of the existing contributing window units within the building. Special attention shall be given to those units located on the same façade as the proposed replacement.
 - For primary facades the new unit shall also match the contributing units in material.
 - For secondary facades with limited contribution and visibility, historic materials or substitute materials maybe considered if it does not compromise other important visual qualities and meets the design requirements.
- Changing the number, location, size, or glazing pattern of windows through blocking in/boarding over, or the installation of ill-fitting or inappropriate replacement sashes or window units will not be undertaken.
- Retrofitting or replacing serviceable contributing windows rather than maintaining them will not be undertaken.
- The HPC may consider substitute materials when use of in-kind material is found to not be technically or economically feasible (as determined by the HPC).
 - When considering substitute materials, it must match the historic in dimensions, profiles, details, color, pattern, reflectivity, finishes and textures. Where it abuts historic materials, its properties must align with that of the historic to ensure compatible expansion and contraction and avoidance of degradation caused by incompatible materials. substitute material cannot lead to the degradation of surrounding historic materials.
- Removing or radically changing windows so that, as a result, the character of the building is diminished will not be undertaken.

BASIC WINDOW COMPONENTS

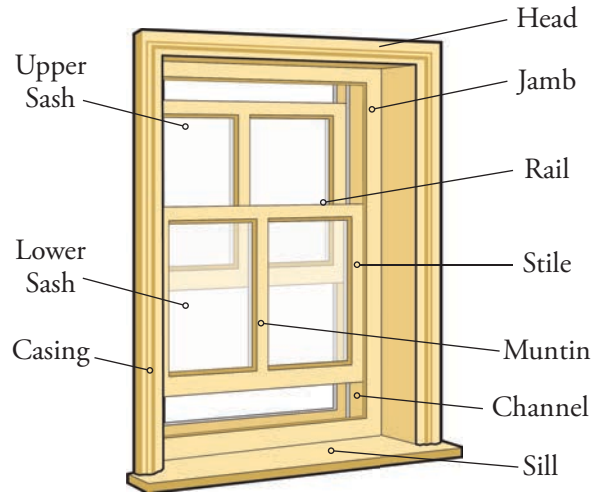

Casement Windows



Double Hung Windows

- Tinted glass, opaque glass, films applied to glass, or glass with less than a 70% visual light transmittance will not be permitted unless it is found to be historically contributing to the building and/or historic feature
- Installing new window openings will be considered for secondary facades if it does not compromise the architectural integrity of the structure or cause damage to or obscure character-defining features (including symmetry, ratios, and proportions). The design of a new unit need not replicate the historic windows, but it must be consistent with the general historic character of the existing contributing window units with the building paying special attention to those units located on the same façade while not creating a false sense of history. This might be accomplished through historic materials or substitute materials if it does not compromise other important visual qualities, meets design requirements, and is located on a secondary façade with limited visibility.
- The removal of historic leaded, stained, or prismatic glass will not be permitted.
- Exterior burglar bars, security grilles/gates and other visually intrusive elements will be considered when an illustrated need exists to address safety and health concerns when all other less intrusive efforts have been exhausted.
- When replacing true-divided light window sashes the new sashes, will either be true divided light units or simulated divided light units with integral muntins. The muntins must closely match the existing in profile, dimension and design and be located on the exterior, and the interior, with spacer bars located in between the glass, to provide as close a match as possible to true-divided light.
- Snap-on muntins, muntins only placed on the interior, and/or only having spacers between the glass will not be permitted as they fail to maintain the historic profiles and design as historic muntins.

WINDOW ACCESSORIES

SHUTTERS

- Historic shutters that are deteriorated beyond repair will be replaced with new shutters that replicate the existing in materials, design, dimensions, placement and features.

APPLYING FOR WINDOW REPLACEMENT

Replacing historic windows is a stepped process

Step 1 – Window Assessment – the existing historic windows must be assessed for their condition to determine if they are repairable or beyond repair. Contributing windows that are repairable are required to be retained and repaired. HP staff offers free window assessments or you can obtain the services of a professional with experience in repairing historic windows to do an assessment. Basic maintenance items such as glazing, re-roping, fit, glass, paint and efficiency are not cause for replacement.

Step 2 – Form Submission – Submit application to replace windows and or sashes that are found to be beyond repair through the assessment. Include in the application:

- Clear description and images of what makes them beyond repair.
- Detailed information and product information for the window you wish to use.
- Fee (Contact HP staff for pertinent fee amount).

Step 3 – Review Process – If the affected units or sashes have been deemed beyond repair by HP staff or the HPC and if the replacement units or sashes are in-kind* the request will follow the HP staff review processes. If the affected units are deemed repairable and/or the replacement units and sashes are not in-kind, the review will follow the HPC review process.

* In-kind refers to matching all facets of the existing including, operation, all dimensions, all design elements and features, material, finish and location. Installation and size relative to the rough opening.

- Missing historic shutters may be recreated utilizing pictorial and/or physical evidence to guide the work matching the historic as closely as possible in design, dimensions, features and placement.
- The introduction of shutters where historical evidence of their presence does not exist will be reviewed based on the architectural style and features of the building to determine if adding

shutters is appropriate or if it will create a false sense of history or architectural conjecture.

- All shutters must be attached to wood elements, if they exist or through mortar joints.
- Shutters will not be installed in a manner that damages historic masonry such as brick, stone and the like.
- Inappropriately scaled/sized or designed shutters will not be permitted.

AWNINGS

- When historically appropriate, the installation of fabric awnings will be considered over windows, doors, storefronts, porches without roofs and, terraces, if they are compatible in scale, form, and design with the building.
- Awnings are reviewed with consideration to the proposed design, location and the architectural design and features of the affected building.
- When approved, awnings will be attached to wood elements or when necessary, attachment may occur through mortar joints of masonry walls.
- Awnings will not be permitted if they damages, destroys or obscure contributing architectural features.
- Awnings will consist of canvas material; vinyl and plastics are not permitted as they do not convey compatible finish.
- Basic awning shapes are triangle/shed in nature with open ends. For the rare arched openings an arched awning may be considered for review.

STORM WINDOWS

Storm windows have been used for over a century to protect windows and provide further relief from the elements. Wood or aluminum storm windows are highly encouraged for historic structures and their review is addressed through HP staff.

- Basic requirements for storm windows:
 - o Fit the opening properly, attached inset to the window stops. Attachment to exterior trim is only considered for approval if inset attachment is not technically feasible.
 - o Storms will be a color that blends with the window sashes. Where affixed to trim, they will match the trim color.
 - o The style of storm will match that of the window. If the window is double-hung the storm will be double-hung; if the sash

is casement the storm will be one piece of glass. For double-hung style storm windows the sash meeting rail of the storm window unit must line up with the sash meeting rail of the window.

GLASS BLOCK

The use of glass block to fill in openings or as an exterior wall is not appropriate, unless it can be proven that the building was constructed with glass block in the affected locations as a historic character-defining feature of the building. The HPC will also consider glass block requests if they meet the following requirements:



- The affected location is below grade.
- Glass block will only be considered in openings that are not visible from or have minimal visibility from the public-right-of way. Consideration is regardless of fences and landscaping as those items are removable.
- Glass block will be considered when the above noted requirements are met and in instances of proven safety issues. Required application information include: illustrated past and current instances of break-ins through subject openings; all other efforts to correct the issue; and, results of those efforts.
- Glass block will be considered when the above noted requirements are met and in instances of continuous water damage when all alternative methods of addressing the issues have been exhausted.
- Glass block will not be utilized to replace existing historic character-defining window units or sashes. Existing historic character-defining window units and sashes will be retained, repaired and preserved and, where necessary, replaced in-kind.
- If approved, glass block must be recessed into the opening as to be flush with the interior wall.
- If approved, the HPC may require screening including but not limited to screens and storm windows. Screening is not a method for approving glass block but is rather a potential requirement should the HPC approve the glass block based on the guidelines noted above.
- The use of vents within glass block will not be permitted as it destroys symmetry and adds an inconsistent feature.



DOORS

Doors and door openings are often character-defining features of a structure. Many styles are associated with specific architectural styles, such as the ¼ lite Craftsman style door. The basic elements of a door are, panels, dimensions, muntins, glass, and proportions. Every effort will be made to preserve, repair, and maintain them. CoA needed.

GUIDELINES

- Retain and preserve doors that contribute to the historic character of a structure, including their functional and decorative features, such as: frames, trim, panels, material, glass, muntins, mullions, leading, sidelights, transoms, fanlights and thresholds.
- Repair, their distinctive features rather than replace, replacement will only be considered if repair is not feasible.
- If replacement of a deteriorated door feature or detail is necessary, replace only the deteriorated

feature rather than the entire door. New features will match the historic character-defining feature in design, dimension, materials, and details.

- If replacement of an entire historic, character-defining door is necessary replace the door in-kind, matching the design, dimensions, panels, pane configurations, trim, details, muntins, material and glass.
- If a door is completely missing (pre-designation), replace it with a new door based on accurate documentation of the historic door or a new design that is compatible with the historic opening and the historic character of the structure. Material for the new door will match existing historic, character-defining, doors in the building, as follows:
 - For primary facades the new door shall also match the contributing doors in material.
 - For secondary facades with limited contribution and visibility historic materials or substitute materials maybe considered if it does not compromise other important visual qualities and meets the design requirements.
- Changing the number, location, size or glazing pattern of doors through the blocking-in/boarding of or the installation of ill-fitting replacement doors will not be undertaken.
- Installation of doors that fail to convey compatible/appropriate finish, details, designs, and proportions and subsequently compromise the historic integrity and character of the building will not be undertaken.
- Installing new door openings will be considered for secondary façades if they do not compromise the architectural integrity of the structure or cause damage to or obscure character-defining features (including symmetry, ratios, and proportions). The design and dimension of a new door and door opening will be compatible with the overall design of the buildings existing historic character-defining doors.
- Changing the dimensions of a historic door opening will only be considered for secondary façades if the change will not compromise the integrity of the structure, cause damage to or

obscure historic features, or cause significant loss or alteration to important ratios and symmetries or features.

- The removal of historic leaded, stained, or prismatic glass will not be permitted.
- Exterior burglar bar, security grilles/gates and other visually intrusive elements will be considered when an illustrated need exists to address safety and health concerns when all other less intrusive efforts have been exhausted.
- Replacement of an existing non-historic door opening will either match the existing opening dimensions or the historic openings.
- When replacing a door with true divided light, the new door will either be true divided light or simulated divided light with the muntins located on the exterior and interior, with the spacers located between the glass. Snap-on muntins, muntins only placed on the interior, and/or only spacer bars located between the glass will not be permitted as they fail to maintain the historic profiles and design of historic muntins.
- The introduction of any new trim in place of, or overtop of the historic trim, such as, brick mould, will not be undertaken. The replacement of historic door trim with new trim that does not replicate the historic trim in all facets will not be undertaken.
- For new openings, the trim will match the historic, character-defining exterior trim on other openings located within the same façade as the proposed new opening. Slight modifications may be considered if required to avoid creating a false sense of history.
- Frosted, tinted, reflective, opaque, or patterned glass is not permitted unless historically present.
- The alteration of primary entrances by adding details not historically present and or documented as a contributing-feature, will not be undertaken.
- The alteration of secondary entrances to make them appear more formal by adding elaborate doors, transoms, sidelights, or other elements will not be undertaken, lest it can be illustrated to have been the historic character of the entry.
- Covering or removing historic transoms and sidelights will not be undertaken.
- The HPC may consider substitute materials when use of in-kind material is found to not be technically or economically feasible (as determined by the HPC).
 - When considering substitute materials, it must match the historic in dimensions, profiles, details, color, pattern, reflectivity, finishes and textures. Where it abuts historic materials, its properties must align with that of the historic to ensure compatible expansion and contraction and avoidance of degradation caused by incompatible materials. substitute material cannot lead to the degradation of surrounding historic materials.

STORM DOORS

Storm doors have been used for over a century to protect doors and provide relief from the elements. Wood or aluminum storm doors are encouraged for historic structures and their review is addressed through the HP staff if they meet the following criteria, for all requests that do not meet these criteria HPC review will be required:

- Fit the opening properly, causing no alteration to existing dimensions.
- Storm doors to be located on street facing elevations will be full lite in design to avoid blocking views of the main doors.
- Storm doors on secondary façades may be full lite, $\frac{3}{4}$ lite, or $\frac{1}{2}$ lite.
- Storm doors will be a color that blends with either the door or the door trim.



BASIC DOOR STYLES
NOT TO BE CONSIDERED
APPROPRIATE FOR EVERY STRUCTURE



Double Doors

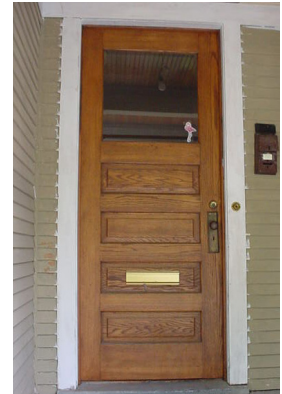

One Third Lite



Half Lite

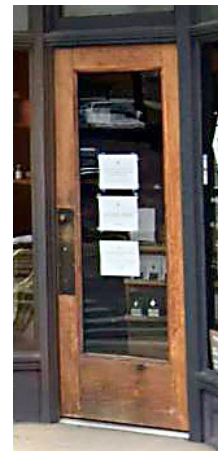

Full Lite

ENERGY CONSERVATION

Historic solid-core wood doors are great insulators. If the owner wishes to further minimize heat loss and improve energy efficiency, the most important step is to reduce air leakage around the door. This can be done by:

- Installing weather stripping along the frame and at the base of the door to ensure the door is properly fitted to the jamb and threshold.
- Securing glazing putty around glazing in the door.
- Installing a properly fitted storm door.
- Low-E or other light absorbing coatings can be considered for storm doors if it can be illustrated that the glass will still appear clear and maintains a minimum 70% visual light transmittance.
- The points above can also be applied to historic windows to improve their energy efficiency

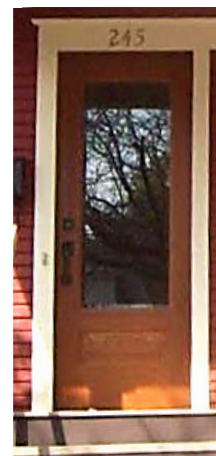

Three Quarter Lite



PORCHES, BALCONIES & STOOPS

Porches, balconies and stoops can be found with or without roofs, and often without solid walls or windows (but may be historically enclosed with screens, glass or other wood details in a one, two or, three seasons fashion), often used as or connected to an entrance or egress from a building. Porches, stoops, and balconies are historically significant, as well as being aesthetic, and functional components of a historic building. Many residential neighborhoods are defined by the rhythm of porches along the streetscape similar to how many commercial corridors are defined by recessed porticos, storefronts, and entries. Porches, stoops, and balconies distinguish the street presence of a structure and contribute to its architectural character. Historically, porches and recessed or enclosed entries provided a buffer between interior and exterior temperature fluctuations and the weather in general. These structures also performed a social function, serving as the location for gathering with neighbors and socializing with passersby. The prominence of these features makes their preservation of primary importance. CoA required.

GUIDELINES

- Porches, balconies, stoops and their functional and decorative features will be identified, preserved, and retained.
- Retain porches, balconies, and stoops that contribute to the historic character of the structure and/or environment, including individual components such as: columns, posts, masonry piers, balustrades (rails and balusters), newel posts, ceilings, floors, steps, handrails, trim and ornamentation.
- Removing or radically changing balconies, stoops, and porches which are important in defining the overall historic character of the building and/or environment will not be undertaken.
- Porches, balconies and stoops will be repaired by using recognized preservation methods for patching, consolidating, splicing and reinforcing.
- Replace in-kind an entire feature that is too deteriorated to repair. Match the historic contributing feature in design, location, dimensions, details, textures, finish and material, using physical evidence to guide the new work.
- If replacement of a deteriorated detail or element is necessary, replace only the deteriorated detail or element, in-kind, rather than the entire feature. Match the original in design, dimension, location, finish, details and material using historic physical and pictorial evidence to guide the work.
- If replacing a historic feature that is missing (pre-designation), replace it with a new feature based on accurate documentation of the historic or a new design that is compatible with the historic character of the building and environment, being careful to be consistent with the design, material, scale, proportions and levels of the structure.
- All exposed wood elements will be painted, with the exception of floors and ceilings, which may be stained or painted.
- Repair of a historic masonry porch foundation will match existing. When replacing missing and/or non-historic masonry foundations they will match the existing or the historic, utilizing historical documentation to guide the work. If such a match is technically or economically unfeasible a compatible new design will be reviewed by the HPC.
- All steps will have enclosed/solid risers.

- The design of a newly introduced porch, stoop, or balcony on a secondary façade will be considered if it does not diminish the building's architectural character, or adversely affect historically contributing features, spacial relationships, massing or scale. The design must be compatible with the building and the site in terms of design, details, scale, placement, proportions and materials.
- Retain the location and character of historic steps.
- Flooring will consist of a wood tongue and groove design with 3" to 4" wide floor boards extended 1" to 2" past the skirt fascia/trim board to ensure proper water drainage. Recessed notches on the visible/exposed surface of the floor, such as, where seams abut, are not permitted, as such features fail to match the historic flooring character and will trap water and debris which can lead to premature deterioration. Alternative styles of flooring will be considered where historic evidence of their existence is found.
- Modern style deck boards are often 5/4" thick by 6" wide with rounded edges are not considered appropriate as the size and design is not historically correct nor compatible.
- Substitute materials for any porch, stoop or balcony feature will only be considered when historic materials are not technically or economically feasible, or, in instances of unusually intense exposure to weather causing repeated in-kind replacement over a short period of time. Such material will need to convey a finish, appearance, details, design, and dimensions that are compatible with the historic character of the building and feature. Should the material abut historic material its properties must match closely to those of the historic to avoid causing deterioration and degradation of the historic material.
- Ceilings will consist of wood tongue and groove or bead board designs, unless historic evidence dictates otherwise.
- The style and material of skirting will match the existing historic skirting, or, where the historic skirting is missing, the new will be compatible with the era, material and design of the historic structure.
- Retain porches, balconies and stoops on the main façade as open, unless it can be illustrated that enclosure of the space is a restoration of a historically contributing feature for the subject building. Consideration will be given to enclosing porches, balconies and stoops on secondary façades with screens or glass and minimal framing



if the change is found to be appropriate for the main building without altering, damaging or obscuring its scale, proportions, sense of transparency, features and ornamentation.

- Historic contributing wood porch floors, skirts, rails, columns, posts and steps will not be replaced with masonry. Likewise, historic contributing masonry porch floors, skirts, columns, posts or steps will not be replaced with wood.
- Building and Housing Code requirements for rail height and spindle spacing is waived in historic districts where the requirements of those codes does not comply with the requirements of the historic district guidelines and Secretary of the Interior Standards.
- For structures that did not historically have handrails placed along steps such installations will be reviewed; to accommodate safety or ease

of access. The design of handrails will be non-intrusive and will be reviewed on a case-by-case basis taking into consideration the structures contributing features, design, massing, scale and spatial relationships.

- Stock, unframed, cross-hatched wooden skirting in a diamond pattern will not be used, as its size and the spacing of members is not historically correct. Lest historic evidence dictate otherwise.
- Pressure treated wood will be considered if it is of appropriate dimension and design, and is painted.

- Please be advised that pressure treated wood is typically wet by nature which may cause it to warp as it dries out and may also affect its immediate ability to hold paint. This is to be taken into consideration as this material, like non-treated wood, must be painted, or for floors and ceilings stained or painted.

- Please be advised that copper is present in treated lumber which causes corrosion of metal hangers and fasteners (often utilized to hold floor joists and structural supports in place). Use of stainless steel connectors and copper or silicone bronze fasteners is recommended

- The introduction of features or details to create a false historical appearance will not be undertaken.
- The HPC may consider substitute materials when use of in-kind material is found to not be technically or economically feasible (as determined by the HPC).
 - o When considering substitute materials, it must match the historic in dimensions, profiles, details, color, pattern, reflectivity, finishes and textures. Where it abuts historic materials, its properties must align with that of the historic to ensure compatible expansion and contraction and avoidance of degradation caused by incompatible materials. substitute material cannot lead to the degradation of surrounding historic materials



EXTERIOR RAILS AND BUILDING/HOUSING CODE REQUIREMENTS

Within a historic district or a historic landmark the requirements of the building and housing codes relating to exteriorly located rails, is waived in lieu of the historic district guidelines and standards. Below is a list of general features of typical historic rails. Please note that these vary depending on the nature and design of the main structure and may not apply to all.

- Average historic rail heights vary from 15” to 32” as measured from porch floor to top of top rail.
- Average historic spindle spacing is the width of the spindle.
- Average space between the porch floor and bottom of the rail is 3” to 5”.
- Porches and stoops that measure less than 30” from floor to grade are not required to have a rail unless, it be historically present.

EXAMPLES OF A BASIC PORCH RAIL AND LATTICE

THESE ARE ONLY EXAMPLES, ALL DESIGNS WILL BE REVIEWED ON A CASE BY CASE BASIS

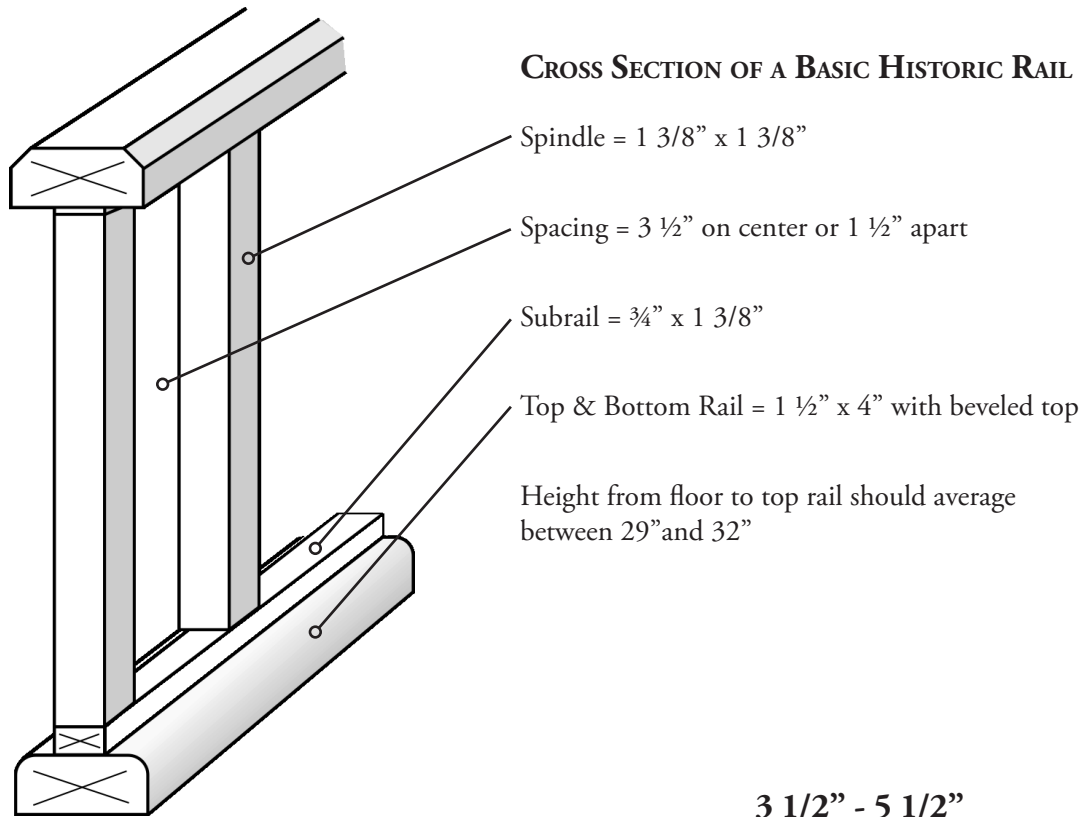

DETAILS OF BALLUSTRADE CONSTRUCTION

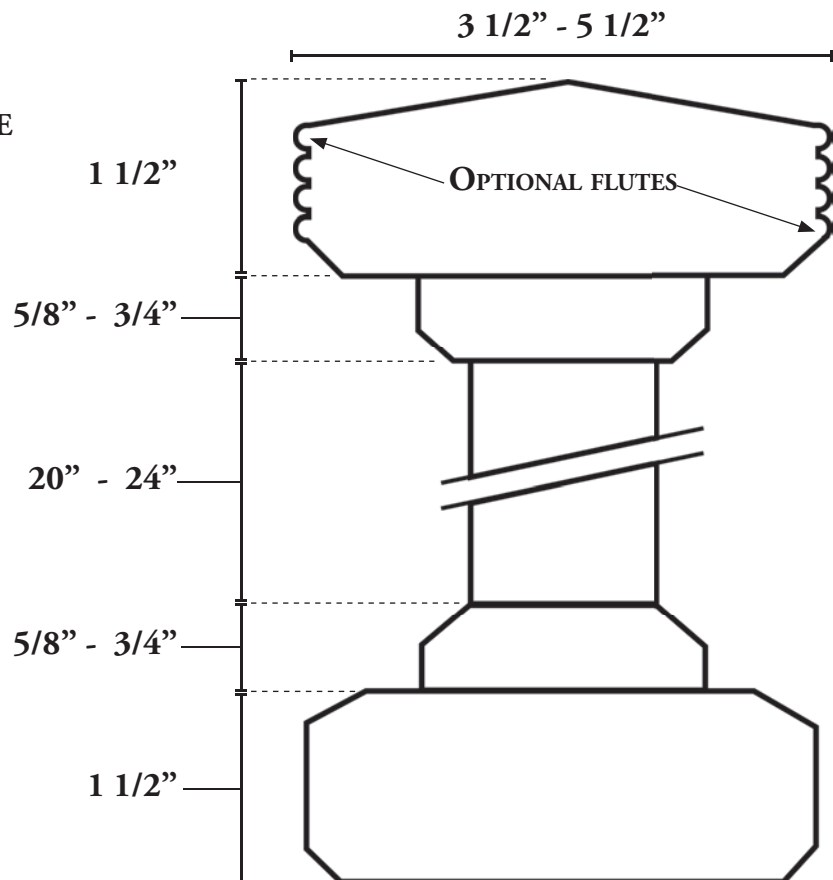

BASIC PORCH DESIGN

THESE DRAWINGS ARE SIMPLY TO ILLUSTRATE A BASIC HISTORIC PORCH THEY ARE NOT
TO BE TAKEN AS A REQUIRED DESIGN FOR ALL PROPERTIES

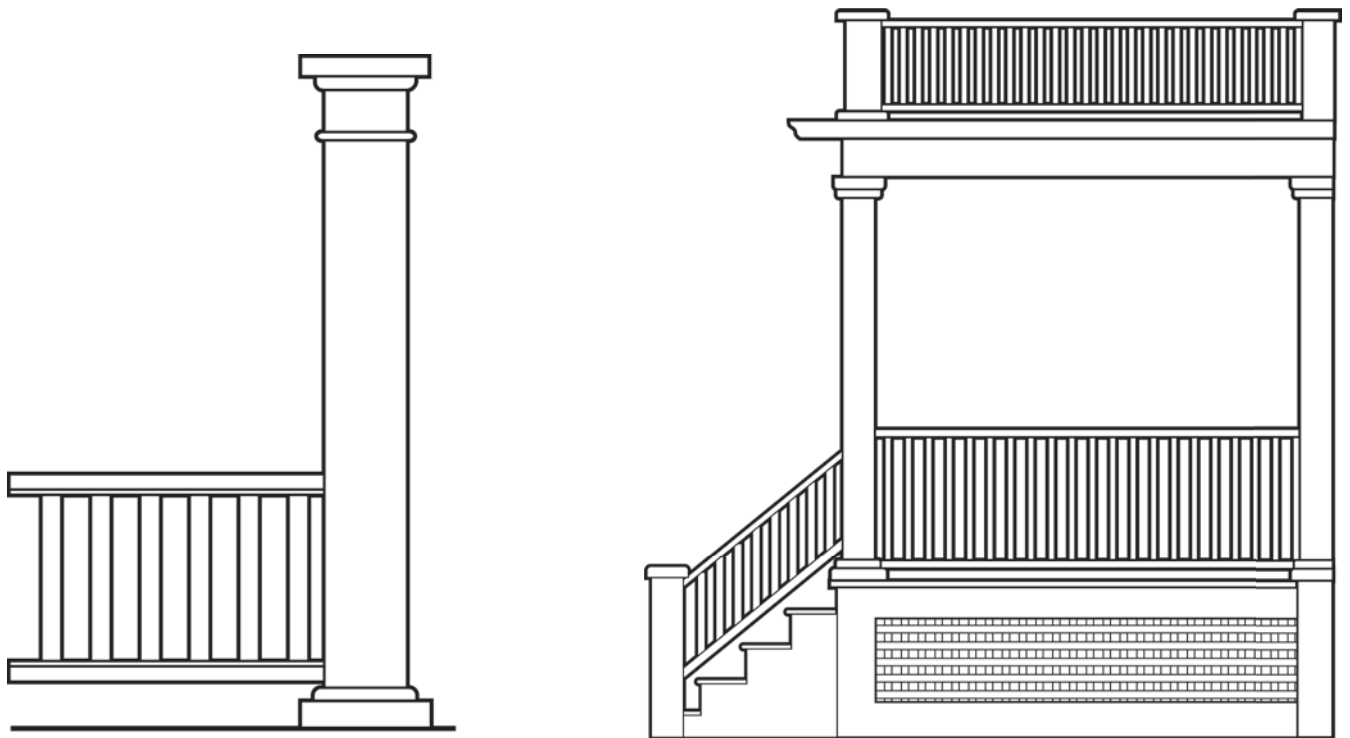
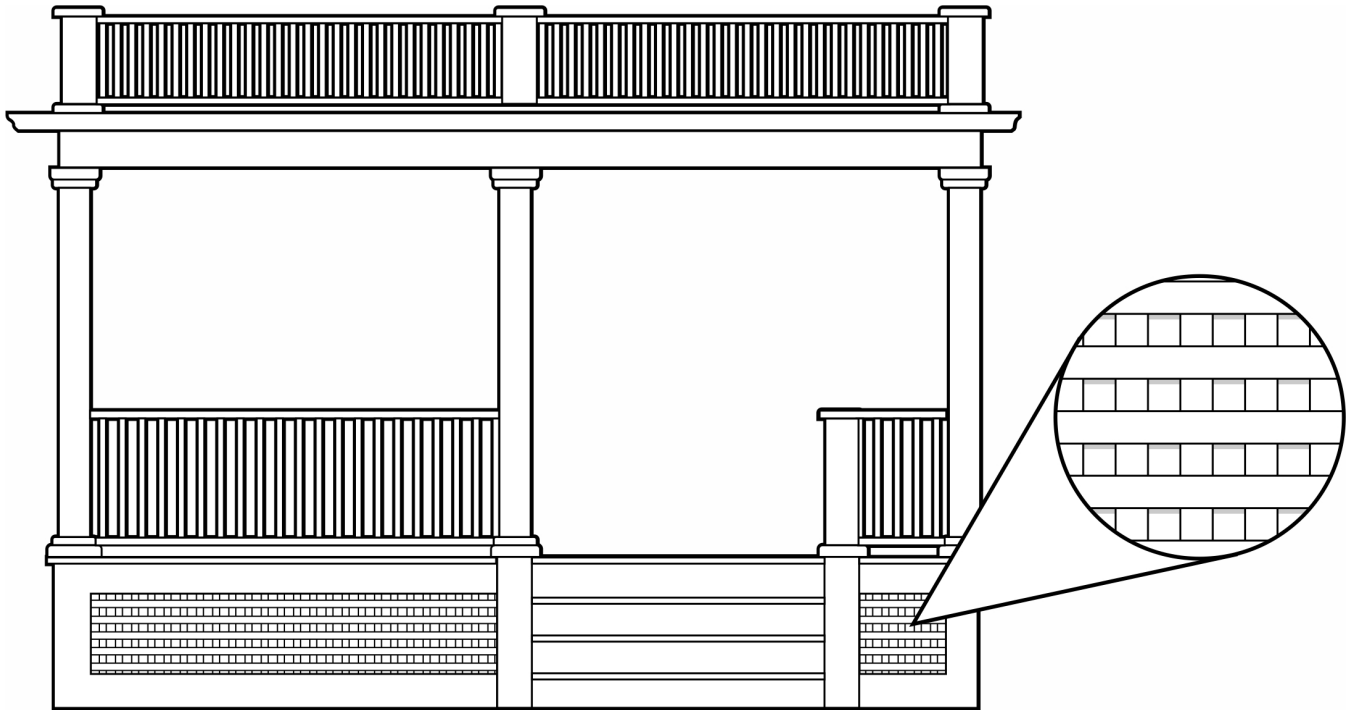

MECHANICAL EQUIPMENT

Mechanical equipment and systems include, but are not limited to, all exterior devices related to heating, electric, plumbing, air conditioning, ventilation, and media (telecommunications, cable and the like). A few examples of such devices and systems are vents, exhaust pipes, cable, conduit, electrical boxes, meters, air conditioning units, generators, antennae, and exterior linesets.

Energy conservation, replacement or upgrade of inadequate utility services, and introduction or upgrade of mechanical systems is a typical concern of property owners. In the historic districts it is important to ensure that such concerns are addressed in ways that do not damage or diminish the historic character of the building, the site, or the district.

The introduction of mechanical systems or changes to existing systems requires review.

GUIDELINES

- New mechanical system, will be installed so that it causes the least alteration possible, both physically and visually, to the building's exterior elevations, site and environment, and the least damage to historic building material.
- Air conditioning units will not be installed in such a manner that historic materials and features are damaged or obscured.
- All mechanical equipment shall be installed in the least visible location possible, typically the rear of the structure. Roof top installations will be considered if it causes minimal damage to historic material, doesn't obscure character-defining features, nor detracts from the character and integrity of the historic structure.
- Mechanical or electrical installations proposed at or near a street façade will require HPC review. The applicant must be able to illustrate that the system is needed and that no less obtrusive locations, exists. Most side and rear yard installation can be reviewed by HP Staff.
- Exterior heating and cooling units will not be attached to historic structures.
- Exterior system lines will enter directly into the structure at the base near the foundation adjacent to the unit.
- Requests for exterior heating and cooling lines may be considered if: it can be determined that the systems are needed; and that there are no alternative methods of installation; and the installation will not damage, obscure, or detract

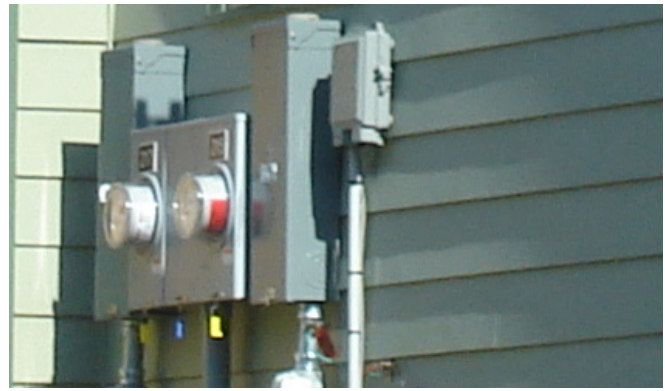

from the historic character of the building and/or its historic character-defining features and materials. Every effort shall be made to house the line sets on the interior of the building. Approval is not guaranteed.

- Portable heating/air conditioning units may be placed in window frames in a manner that protects the sash and frames. Such installation will be considered only when all other viable heating/cooling systems would result in significant damage to historic materials and features. Such installations are seasonal; heating systems may only be in place from October 1st to June 1st while A/C units may only be in place from June 1 to October 1st. Such installations will not result in the removal of a window sash nor can they be attached to or penetrate exterior walls.
- The existence of other historically inconsistent work in the area is not a basis for approval of another inconsistent feature. Such inconsistent work often predates the district or has special circumstances.
- When mechanical equipment is affixed to a building, such as masts and electric meters, it must be installed to avoid damaging the structure. For example, when affixed to a masonry structure, it will be attached to mortar joints, not the brick or stone.
- Mechanical equipment will be low to the ground and use as little space as possible. This will decrease the visual impact, while also enabling the installation of appropriate screening.
- Visual and physical effects to the structure or neighborhood must also be taken into account. When the equipment require screening or camouflage to be appropriate the HPC may dictate that the equipment be painted to match the structure or that a fence be erected or other forms of screening.

- The installation of communication towers within the boundaries of a historic district or landmark is not appropriate.
- Cutting through, obscuring or covering over historic character-defining features to install mechanical equipment will not be undertaken

REVIEW PROCESS FOR MECHANICAL EQUIPMENT

Review requirements are based on location and impact. Listed below are review requirements.

- Rear: If the above noted guidelines are met for equipment located at the rear of the property, with no visibility from the right-of-way, HP staff may review the application. This does not apply to properties located on a corner lot.
- Side: If it is impossible to locate the equipment in the rear, the side near the rear yard or walls is the next preferred location. If the above noted guidelines are met then HP staff may review the application, when visibility from the public right-of-way is minimal. Installation proposed for the side of property toward the front may require HPC review.
- Front: The least compatible location for mechanical systems is on the front façade and in the front yard or along the sides near the front. Placement in the front, or towards the front results in a negative visual impact to the historic building and district. If the only possible location for the new equipment is in the front the application will indicate that the system, if approved, would be installed in a way that incorporates it into the façade design while causing no damage to the structure or its features, such as through the use of screening materials. The installation of mechanical equipment in the front or side yards near the front or attached to the front façade or side elevation near the front will require review by the HPC, noting approval is not guaranteed.
- Corner Lots: Due to the high visibility of corner lots, it is recommended that applicants work with HP staff to determine the best location. If the chosen location will cause significant visual impact or damage to the building, or is on a street façade,, the application will require HPC review.
- Commercial Equipment: All efforts should be made to house such equipment on the interior of the building. Where this is not possible, roof top installation is the preferred location for commercial structures. It will be installed so as not to be visible



Proper grade placed A/C units with direct line installation



Improper installation of exterior equipment and lines can have a detrimental impact on the character of a structure.

from the ground and will not cause damage to, or obscure, architectural details. When rooftop installation is not an option, the equipment will be located adjacent to the least visible façade, as stated above. Equipment attached to the façade will need to be done in such a manner as not to destroy or cover architectural elements and materials. HP staff may review these installations in locations that are not visible from the public right-of-way and do not damage or obscure architectural details, or materials.



Appropriate placement: Rear of building

SATELLITE DISHES

Satellite dishes are communication devices that allow viewer to receive video programming signals from direct broadcast satellites, multi-channel multipoint distribution providers, and television broadcast stations.

Local historic district/preservation commissions may not deny the installation of a satellite dish or antenna, per the Federal Communications Commission. However, the placement of the satellite dish and antenna's may be regulated by historic district/preservation commissions. The Commission's objective is to be consistent with the FCC ruling while avoiding highly visible installations that significantly affect the visual character of a structure and its surroundings or that damages character-defining architectural details and materials.

GUIDELINES

- A satellite dish and antenna will be placed in the least visible location possible.
- Whenever a satellite dish or antenna is affixed to a building, it will be installed to avoid damaging or obscuring the structure and any of its contributing features. For example, when affixed to masonry, it will be attached to the mortar joints and not the brick or stone.

REVIEW PROCESS FOR SATELLITE DISHES

Review requirements are based on location and impact. Listed below are review requirements.

- **Front:** Any dish proposed to be located in a front yard or on any portion of the front façade or front facing roof planes will require HPC review. Such



Inappropriate placement: Front yard

installations will only be considered when no other, less visible location exists.

- **Rear (not applicable to corner lots):** When possible all equipment will be located at or near the rear without damaging or obscuring character-defining features and materials. Review is conducted by HP staff.
- **Side and Front (not applicable to corner lots):** Any dish located on the rear two-thirds of the side elevations of a structure or side yards of a lot, where it will have limited visibility from the public right-of-way, will only be considered when a non-visible location is not an option. Equipment in these locations will require a HP staff review. Equipment on the front 1/3rd of a building or yard will only be considered when no less visible location exists. Such placements will require review by either HP staff or the HPC.
- **Corner Lots:** A corner lot has two front yards (those facing a street), two side yards, and no rear yard. As with any other property the goal is to place the equipment in the least visible location possible. Locations that have limited visibility will be reviewed by HP staff, while those with higher visibility and/or located in front will require HPC review.
- **Vacant Lots:** Where there is no primary building on the property, either because it is a vacant lot or in cases where the designation is of an object or site, the HPC will review the location and any proposed screening material on a case by case basis.



OUTBUILDINGS

Outbuildings are small enclosed structures typically utilized for storing yard equipment, bikes, and other items, or for play, and are commonly referred to as sheds or playhouses. Such buildings can be custom built and designed or a prefabricated kit. For examples of potential designs see page 77. Outbuildings that meet the guidelines below will be reviewed by HP staff; all others will require HPC review.

GUIDELINES FOR HISTORIC OUTBUILDINGS

- Retain and preserve historic out buildings and their features as well as features that contribute to the historic character.
- Repair historic character-defining features in-kind.
- Replace historic character-defining features in-kind that are too deteriorated to repair using physical and pictorial evidence to guide the new work.
- Design a new feature for an outbuilding when the historic feature is missing (pre-designation), basing it on historical, pictorial and physical documentation or design a new feature that is compatible with the historic character of the building and site.
- Removing an entire historic feature whether it be a historic outbuilding or a contributing feature of a historic outbuilding, that is unrepairable and not replacing it; or replacing it with a new feature, or structure, that does not convey the same visual appearance will not be undertaken.

GUIDELINES FOR NEW OUTBUILDINGS

- Will be placed in rear yards towards the back of the properties with one such building per site, unless receiving special approval from HPC and Zoning. Outbuildings are prohibited in front yards and shall only be considered for side yards in the case of corner lots.
- Will be free standing; attachment to another structure is not permitted.
- Outbuildings will not exceed 120 square feet in size. It will have a height no taller than 14 feet as measured from adjacent grade to the middle of the roof rake and walls no taller than 8 feet.
 - Outbuildings exceeding these dimensions are considered garages (see garage section of guidelines, pages 77-80) and will require HPC review, Zoning review, and a Building permit.
- Retain the historic relationship between buildings, landscape features and open spaces.
- Introducing any new building that is out of scale, visually incompatible in terms of size, design, materials and texture or which destroys historic relationships on the site shall not be undertaken.
- For corner lots, outbuildings will be located in a side yard towards the back property line away from street facing façades, in the least obtrusive location possible.
- Roof design will be shed, flat or gable. Gambrel or “barn” style roofs will not be utilized as it is not reflective of historic urban structures.
- Roofing material can range from asphalt shingles & metal to a more natural product such as slate, tile and wood shakes.
- Temporary or mobile outbuildings that are preformed complete shells such as “Rubbermaid” will require review when their size exceeds 4 feet by 4 feet. Such portable storage units that are under the 4’ x 4’ dimension will not require review if: it is placed in a rear yard, is not against or attached to a structure, and has no footings or pad.
- Exterior materials will be compatible with historic materials appropriate to the main structure and the neighborhood. They may include traditional materials such as wood, stucco, and masonry or modern substitute materials if it is compatible and does not detract from the historic character and integrity of the site, main building, and district. Consider dimensions, profiles, details, finishes, and textures.
- All windows and doors for new outbuildings are to be made of wood, clad wood, or other materials that convey historically compatible visual qualities when considering, design, dimensions, finishes and textures.

EXAMPLE OUTBUILDINGS

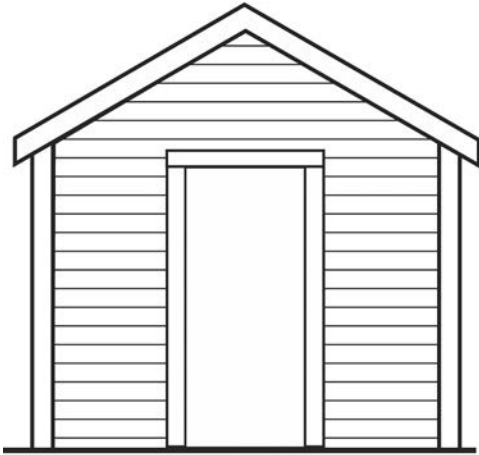

Example of Outbuilding with Gable Roof

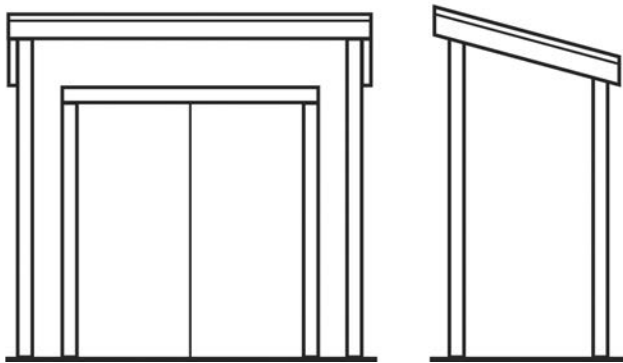
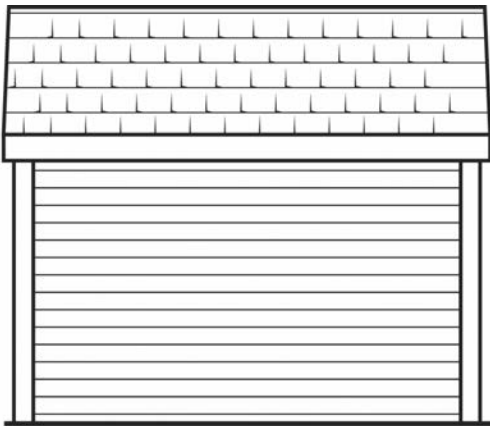

Example of Outbuilding with Shed Roof



GARAGES & CARRIAGE HOUSES

Garages and carriage houses are important historic resources, as such, every effort will be made to preserve historic contributing garages and carriage houses.

Carriage house refers to an enclosed outbuilding that is usually more than one story tall that was typically designed to house carriages, horses and/or automobiles on the first floor and storage, hay, or servants on the second floor. Garage refers to an enclosed outbuilding that is more than 120 square feet in size, one to one and a half stories tall, and typically utilized to house automobiles and other yard tools. Repair, replacement, and new construction of garages and carriage houses will require review.

Most carriage houses were designed to complement the main structure, while early garages were often bought ready built and were simple structures. The movement to match or compliment the garage to the main structure did not begin in earnest until the 1920s and 1930s at which time garages were often being constructed at the same time as the house.

GUIDELINES FOR GARAGES & CARRIAGE HOUSES

- Retain and repair historic contributing garages and carriage houses in their historic locations.
- Retain historic character-defining materials, configuration, massing, scale, roof shape and pitch, placement of doors, windows and other features.
- Replace character-defining features that are deteriorated beyond repair with new that match the existing in design, material, dimensions, operation, profiles, location, finish and details.
- Altering the design of a historic garage or carriage house to be inconsistent with their historic character will not be undertaken.

- Demolition of contributing historic garages and carriage houses is not appropriate.
- Additions to historic contributing garages and carriage houses will be considered if subordinate to the mass of the existing structure (mass relates to square footage, width, depth, and height), its size and placement does not overpower nor detract from the historic character of the building. The design will be simple and shall clearly illustrate what is new avoiding a false sense of historical development but at the same time it must be compatible with the historic building. The roof of the addition shall be located below that of the roof ridge of the historic building and the shape shall be compatible with the historic structures roof shape.
- Additions must be located in such a manner as to not detract from, nor over power the historic building.
- Set additions back from the street facing façade.
- Exterior materials will be compatible with historic materials appropriate to the historic structure the addition is attaching to as well as the main building on the site and the district. They may include traditional materials such as wood, stucco, and masonry or modern substitute materials if it is compatible and does not detract from the historic character and integrity of the historic building, main building, and district. Consider dimensions, profiles, details, finishes, and textures. All windows and doors for new additions must convey historically compatible visual qualities when considering, design, dimensions, finishes and textures.
 - Any material must match the historic in its texture, finish, design, dimensions, and details. Where materials about the properties of the new material must be compatible with the existing materials to ensure appropriate expansion and contraction and to avoid all potential chemical reactions. Introduction of a substitute material cannot lead to the degradation of surrounding historic materials.

GUIDELINES FOR GARAGE AND CARRIAGE HOUSE AUTOMOBILE DOORS

Automobile doors are one of the most significant character-defining features of these structures. The doors can be decorative or utilitarian in nature and vary in operation from swing (hinged), sliding, folding, flip up and roll up. Every effort will be given to protect, maintain, and preserve these features.

- Retain historic character-defining garage and carriage house doors.



Example of Historic Garage Doors

- Where possible, repairing and re-hanging historic character-defining doors will be undertaken. Should repair and/or replication of the character-defining historic door operation no longer be technically feasible, an alternate method of operation for the historic door will be reviewed by the HPC.
- Altering historic openings for new doors will not be undertaken.
- The repair of a historic feature or portion of a feature that is too deteriorated to retain the new shall match the existing in, design, dimensions, operation, location, and materials.
- Only when a historic contributing door is beyond repair will replacement of the entire door be considered. Such replacement shall be in-kind matching the design, details, dimensions, profiles, features, finish, location, operation and when technically and economically feasible, material.
- When a historic contributing door is beyond repair, and matching the historic door is technically and economically not feasible, a proposed replacement door will be considered that contains some of the elements of the historic door or a new design that is appropriate for the period and design of the structure. HPC review required.
- When replacing a non-contributing door or replacing a missing (pre-designation) door, it is preferred, but not required, that the new door match the documented historic doors of the building. Alternatively:
 - When replacing non-contributing or missing doors, new doors will be compatible with the historic character of the building.

- o When replacing non-historic or missing doors the new will be compatible in quantity of doors, height, width, proportion, trim, corner details, and pattern of panels, and glass.
- o When replacing non-historic or missing doors an alternate material with appropriate design will be considered.
- Installing a door that is not compatible with the structure will not be undertaken.
- Installing a door that detracts from or covers historic features will not be undertaken.
- Removing character-defining features and not replacing them in-kind will not be undertaken.
- The HPC may consider substitute materials when use of in-kind material is found to not be technically or economically feasible (as determined by the HPC).
 - o When considering substitute materials, it must match the historic in dimensions, profiles, details, color, pattern, reflectivity, finishes and textures. Where it abuts historic materials, its properties must align with that of the historic to ensure compatible expansion and contraction and avoidance of degradation caused by incompatible materials. substitute material cannot lead to the degradation of surrounding historic materials.



New Garage Example



New Carriage House Example

GUIDELINES FOR CONSTRUCTING NEW GARAGES OR CARRIAGE HOUSES

The construction of new garages and carriage houses will follow the New Construction Guidelines (pages 80-83) as well as the guidelines below. In evaluating the appropriateness of proposed new garages and carriage house, the HPC will review the project to determine if it is subservient to the primary building and environment, and is compatible with the character-defining qualities of the site, primary building, and environment. Environment refers to the immediate historically designated area and its contributing structures and features. Areas located outside of the boundaries of the historic district and/or non-contributing buildings and features within the district are not reference points for determining compatibility nor character.

- Design new garages and carriage houses to be compatible with the primary building on the lot, as well as the adjacent historic environment and neighborhood.

- Design new garages and carriage houses to be visually compatible with the property and the district in terms of massing (square footage, width, depth and height) and materials. Noting the massing is to be subservient to (smaller than) the primary building on the lot as well as compatible with the surrounding historic environment.
- Utilize roof shapes and pitches that are consistent with the primary building or with contributing accessory structures historically found in the adjacent neighborhood.
- Select exterior materials that are visually compatible with historic contributing materials found on the primary building in finishes, features, dimensions, and design.
- Choose windows and doors that are proportionately consistent with the size of the garage or carriage house and which draw from the design of the contributing historic windows and doors on the primary building.

NEW GARAGE AND CARRIAGE HOUSE PLACEMENT

- Garages and carriage houses will not overpower or detract from the primary building, adjacent primary structures, or environment.
- Massing (combination of square footage, width, depth and height) and scale will be compatible with the historic character of contributing accessory buildings in the immediate historic district while remaining subservient to the primary structure on the site.
- Retain historic relationships between the primary building, open space, and landscape features when siting a new garage or carriage house.
- New garages and carriage houses will be located in the far back of the rear yard. Such structures must be free-standing, they may not be attached to another structure either directly or indirectly (such as through the use of covered or enclosed walks/additions). Except:
 - o When historical evidence illustrates that a garage was historically attached to the main building as a contributing historic feature. Or,
 - o When the historic character of the environment and/or main building dictates otherwise and when all other guidelines and standards are met. Or,
 - o When unique topography, features or terrain exists and when all other guidelines and standards are met.

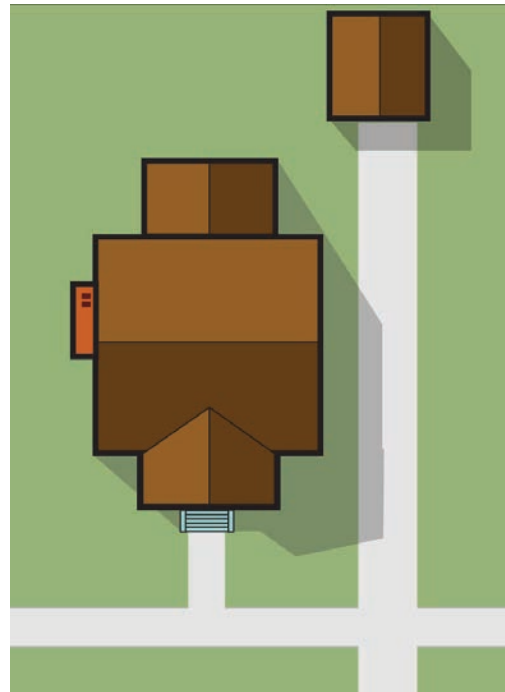

PROPER PLACEMENT

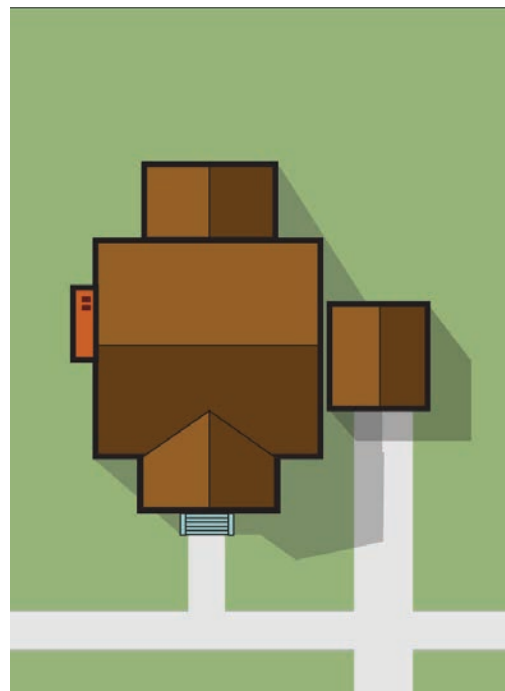

IMPROPER PLACEMENT

ADDITIONS TO HISTORIC BUILDINGS

During the continued life of a building, there is often a need to adapt it to provide additional space. New additions within historic districts can be appropriate when they respect the historic character, features, design, and scale of the primary building and the surrounding historic district. On the other hand, an inappropriate design can result in an irrecoverable loss of historic character. As such, every care will be taken when reviewing requests for additions, especially as it relates to the design, scale, massing (width, depth, height, square footage), material, and location. HPC review required.

GUIDELINES

- Place new additions on secondary defining elevations so as to be as inconspicuous as possible; typically the rear.
- Attaching additions so that the character-defining features of the historic building are obscured, damaged or destroyed will not be undertaken.
- The height of an addition will be lower than that of the primary building.
- The addition will be narrower than the primary structure.
- The primary structures will maintain a footprint that is at minimum 1/3 greater than the size of an addition's footprint.
- Additions will not project closer to the street than the primary structure (this includes the front facade and porches).
- Roof forms will be as consistent as possible with the pitch of the roof of the primary structure or be appropriate to the style of the structure. For example, a front gable house could potentially have a shed roof or hip roof addition if the roof pitch is correct.
- The size and design of new openings, their position, and rhythm on the addition will relate to the primary structure.
- The ratio of window area to solid wall for all façades will be compatible with the primary structure.
- Materials will be selected to complement the primary structure and may include historical materials or the use of alternative materials if the overall design, details, textures, and finishes are compatible with the primary structure and the surrounding historic district and if the materials do not abut historic materials.
- Additions that would significantly alter the historic structural system of the primary structure will not be undertaken.
- Additions that would change the orientation of the primary entry on the primary building will not be undertaken.
- New additions will respect and be subservient to the massing, scale, and setbacks of the primary structure and surrounding contributing structures.
- The size of an addition will be limited so that it does not diminish or visually detract from the primary structure or district.
- Linking corridors, known as “hyphens,” will be considered when appropriate as a method to link a primary structure to a large addition or as a method to avoid loss of historic features.
- Additions will not result in changes to the shape and pitch of the primary roof.
- Simplified details that reference the character of the primary building will be considered.
- Designs that starkly contrast with the primary building and call undue attention to the addition will not be undertaken.
- Construct a new addition so that there is the least possible loss of historic materials and so that character-defining features are not obscured, damaged, or destroyed.
- Design new additions in a manner that makes clear what is historic and what is new.



- Design for the new work can be contemporary or reference design motifs from the historic building. In either case, it will be compatible in terms of massing, materials, relationships, location, design and features.
- New additions will be designed to be compatible with the original building yet at the same time discernible from it. For example: it can be differentiated through a break in roofline, cornice height, wall plane, materials, siding profile, or window type.
- A new addition will be designed and located so that significant site features, including mature trees, are not lost.



ROOFTOP ADDITIONS

Rooftop additions are generally limited to small mechanical penthouses on commercial or industrial buildings or dormers on residential buildings. Larger roof top additions that could alter the perception or actual massing and scale of the primary building will fall under the larger umbrella of Additions Guidelines noted above in addition to:

- Such additions will not alter the massing and scale of the historic structure.
- Such additions will be placed where they do not detract obscure, damage or destroy character-defining features.
- Such additions will not be placed on or toward a front or street facing elevation.
- The scale of such structures will be proportionately consistent with the primary building.

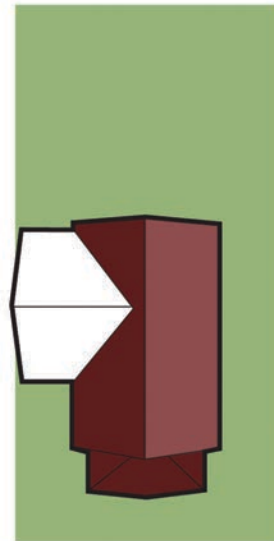

Inappropriate Addition

- Massing and scale competes with and, significantly alters, the massing and scale of the historic house.
- Location detracts from and creates a significant loss of historic design and integrity.
- Adds a false sense of history and development to the structure.





**POTENTIALLY
APPROPRIATE ADDITION**

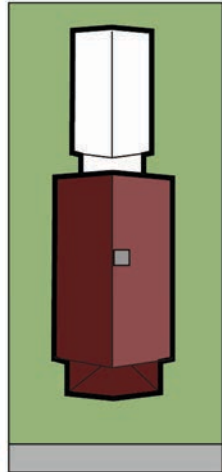

**POTENTIALLY
APPROPRIATE ADDITION**

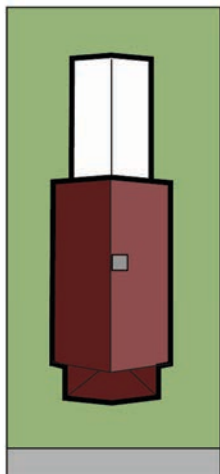

CONSIDERATIONS WHEN PLANNING AN ADDITION

When planning an addition, it is important to be aware of the factors that the HPC will consider in its review of the appropriateness of the proposed addition.

- Does the addition diminish the ability to interpret the character and vintage of the original building?
- Does the addition detract from the primary building or adjacent properties?
- Does the addition require significant alterations or removal of character-defining features?
- Does the addition require structural changes to the original building?
- Is the massing of the addition subordinate to the historic building mass?
- Is the addition offset from the historic building to provide differentiation?
- Is the design simple and compatible with the character of the historic building and surrounding properties?
- Could the addition be removed in the future without causing irreversible damage to the historic building?

Potentially Appropriate Addition

- *Massing and scale is subservient to that of the historic house.
- *Location is stepped back and at the rear thus not competing with the design and integrity of historic house.
- *Recognized as an addition yet draws from the main building.

NEW CONSTRUCTION

Designing a new building to fit within a historic district requires careful planning and an understanding of the area's distinctive historic architectural character in order to determine the basic features and massing that reinforces this character. New construction designs can be "traditional" or "contemporary". As it pertains to "traditional" designs, the replication of historic features will not be undertaken as it creates a false sense of history, however, it is acceptable to utilize historic designs and features as a basis for creating traditionally designed new construction. "Contemporary" designs, can add depth and interest to a district IF the new design reflects an understanding and compatibility with the historic character of the immediate designated district.

The success of new construction within a historic district relies on understanding the distinctive character, massing, layout and features of the district and ensuring compatibility with them. The following elements are particularly critical in considering the design of new construction within a historic district: location, placement, orientation, setbacks, site features, patterns, spatial relationships, massing & scale (width/depth/height), roof shape, proportions, ratios of solid to open, and material design and finishes. HPC review required.

Examples:

- If the historic context consists of structures that are more vertical in massing and openings, the new construction will follow suit, as the introduction of a horizontal structure would be out of character.
- If adjacent structures are at the sidewalk or 15' back, the new structure will be placed similarly in order to maintain the historic streetscape and vistas.
- If structures all have driveways on the left with regular spacing between houses of 10' on the right, such a pattern will be maintained with the new construction.
- If the nearby structures are typically two stories in height the new construction will be very close to the same height.

GUIDELINES

for site guidelines see Environment and Site

Given the immense size of many districts, to determine compatibility one must look to the immediately surrounding and adjacent contributing historic structures, vistas, and environments located within



the same historic district as the subject property, as it is these areas that will be directly and indirectly affected. Immediate surrounding area typically accounts for approximately 3 blocks around the subject property (it may be more or less depending on existing structures, topography and the scale of the proposed building) and again only relates to those contributing structures within the district boundaries. Should a site be located near the edge of the district properties located outside the boundary cannot be utilized to determine character and compatibility.

- Retain site features that are important to the overall historic character.
- Retain the historic spatial relationships between buildings, landscape features, and open space.
- A new building will be designed to be compatible with the historic character of the site, district and neighborhood.
- New construction siting will be reviewed based on existing district setbacks, orientation, spacing, and distance between adjacent buildings.
- Design new construction so that the overall character of the site, site topography, character-defining site features, and district vistas and views are retained.
- Conform to design guidelines involving the site and environment (see pages 41-45).
- Design new buildings to be compatible with surrounding buildings that contribute to the

historic character of the historic district; in terms of height, form, size, scale, massing, proportions, and roof shape.

- Utility connections will be placed to minimize visibility from the street.
- Design the spacing, placement, scale, massing, orientation, proportion, and size of window and door openings to be compatible with surrounding historic buildings.
- Utilize windows and doors that are compatible in finish, texture, subdivision, proportions, patterns, and details with the character-defining windows and doors of surrounding historic buildings.
- Select materials and finishes that are compatible with character-defining contributing historic materials and finishes found in surrounding historic buildings.
- Design new buildings so that they are compatible with but discernible from adjacent historic buildings.
- The consolidation of lots into a larger property that disrupts the character-defining patterns of the historic district should not be undertaken.
- The front entrance will be orientated towards the main street unless it can be illustrated that the historic character of the surrounding contributing historic properties dictates otherwise.
- Front porches are often a significant character-defining feature of a district, should this rhythm and design exists in the surrounding historic environment, the new construction will incorporate a front porch to maintain that spatial relationship, scale, and appearance of the district. The porch may be traditional or modern in design if it is compatible with the surrounding contributing historic character.
- Maintain the established scale and massing (height, width and depth) of the street by designing new buildings to be within the established range of height, massing, and form of the adjacent contributing structures of the historic district.
- Use floor-to-ceiling heights that are consistent with those in the district to ensure that exterior proportions and scale are similar to surrounding contributing historic structures, paying special attention to exposed foundation heights.
- Massing in historic structures is often broken up through vertical and/or horizontal articulations;

these methods should be utilized on new construction in a manner compatible with the subject properties immediate surrounding, contributing, historic character.

- Balance façade proportions with those historically found in surrounding historic structures. The composition and scale of façade elements, such as porches, windows, doors, siding, and trim can significantly affect the aesthetic of the district.
- Contemporary materials will be considered for new construction as an expression of its own time when the products features, such as, scale, proportions, finishes, textures and details are compatible with the character-defining materials of the immediate historic district. Materials such as vinyl and aluminum do not convey the same visual qualities, design, profiles, finishes, textures or installation as historic materials and as such are not compatible.
- Use materials with traditional dimensions and proven durability.
- Substitute materials designed to replicate wood will be reviewed for new construction when it has a smooth finish and appropriately proportioned reveals and profiles.
- Faux wood grain finishes will not be permitted.
- Maintain established ratios of solid wall spaces to openings.
- Select a roof form and pitch that is compatible with the established precedents within the surrounding historic district.
- Contemporary interpretations of traditional details such as, cornices, lintels, brackets, windows, doors, siding and chimneys, are encouraged, but avoid creating a design that is overly simplified as it will stand in stark contrast to the rich architectural variety within the historic district rather than being compatible with the character.

INFILL HOUSING EXAMPLES



444 UNION SE

- Façade Proportions are maintained
- Consistent materials are used
- Consistent roof forms
- Consistent building heights

New structure maintains similar shape, massing and setback as existing structures.

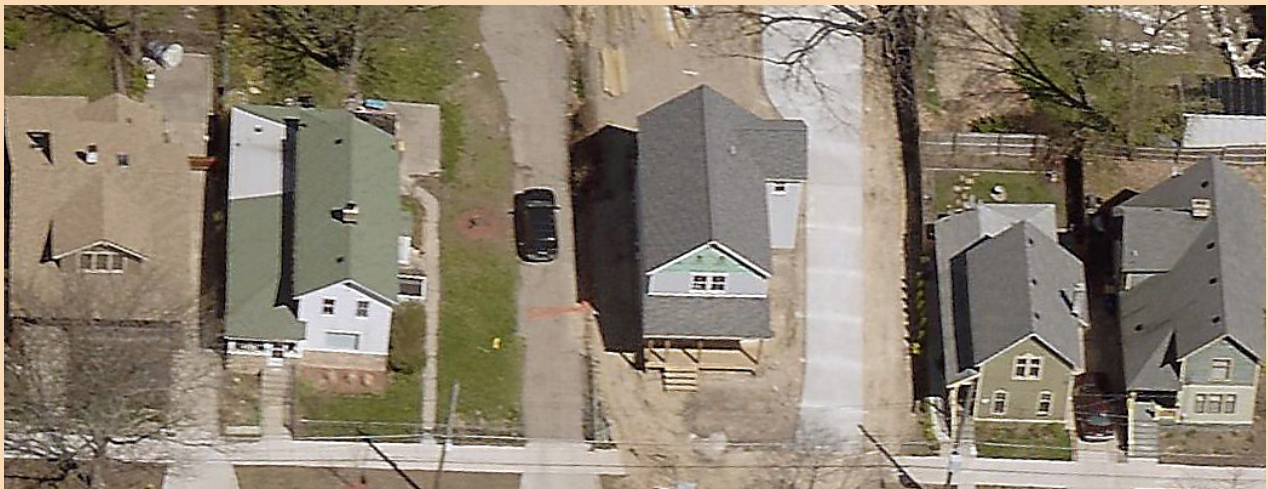

NEW CONSTRUCTION SPACING

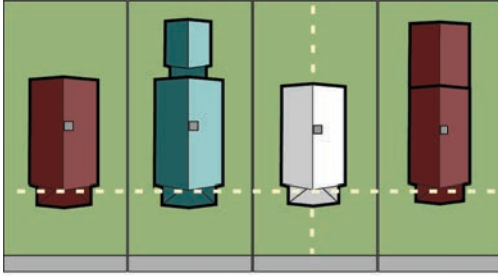

APPROPRIATE

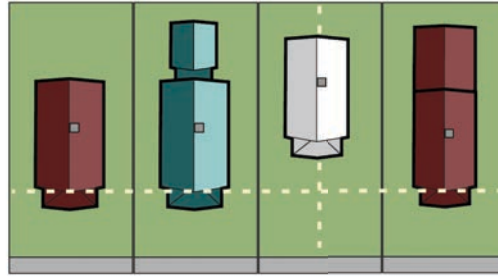

INAPPROPRIATE

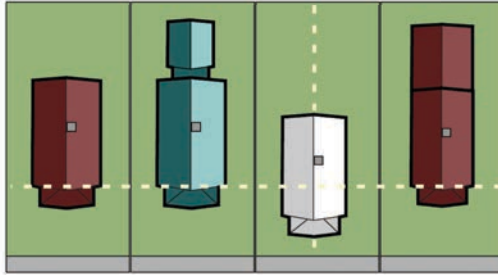

INAPPROPRIATE

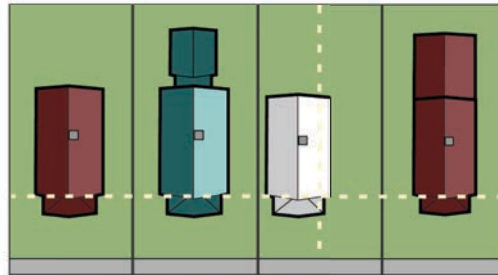

INAPPROPRIATE

NEW CONSTRUCTION MASSING (EXAMPLE ONLY)



NEW CONSTRUCTION HEIGHT (EXAMPLE ONLY)



STOREFRONTS

For most historic commercial buildings the storefront is one of, if not the most important, architectural feature. As such, every effort will be made to retain and repair character-defining historic storefronts. Storefronts are the most prominent features of the building with the most impact to the building itself and also to the streetscape and historic character of the district. Not only is it important to retain historic storefronts but it is also important to ensure that new storefronts are compatible to the primary building as well as the streetscape. Typical functional and decorative features of a storefront include, but are not limited to, large display windows, recessed entries, full light doors, transoms, bulkheads, cornices, pilasters, columns, entablatures, prismatic glass, panels, signs, awnings and the proportions and relationships of the features. CoA required.

GUIDELINES

- Protect, maintain, preserve, and retain storefronts and their functional and decorative features that are important in defining the historic character of the building, such as: display windows, recessed entries, transoms, bulkheads, doors, columns, pilasters, cornices, entablatures, brackets, decorative glass, and all other details. They will not be obscured, damaged or destroyed.
- Repair character-defining storefront features in-kind, that are beyond repair, using recognized preservation methods for patching, consolidating, splicing and reinforcing.
- When replacement of a deteriorated feature is necessary, replace only the deteriorated detail rather than the entire feature. All repairs and replacements are to be in-kind, matching the historic design in all facets including dimensions, texture, location, and materials.
- If the entire feature is beyond repair and must be replaced it will be replaced in-kind matching the historic feature in all facets including design, dimensions, details, texture, location, and material.
- Storefront glass, display windows, transoms, and door glass.
 - o Glass must be clear. Tinting, shading, coloring, applied films or other means of darkening or limiting transparency that is directly applied to or part of the glass and its system is not permitted.
 - o Interior treatments such as, but not limited to, blinds, curtains, drapes, walls or other treatments designed to limit visibility and/



Example of a Historic Storefront

- o or light into the building that are located adjacent to or within three (3) feet of the storefront glass, display windows, transoms and/or, door glass are not recommended and will require review by the Historic Preservation Commission. The commission shall review for impact to the directly affected structure as well as the surrounding historic streetscape character.
- o Other means of blocking view and/or light into the space such as creation of solid interior walls or other solid barriers taller than three (3) feet in height (as measured from finished floor) and located more than three (3) feet from the storefront glass, display windows, transoms and/or, door glass shall be reviewed by the Historic Preservation Commission to determine impact to the directly affected structure as well as the surrounding historic streetscape character.
- o At no time shall any approved interior installation prevent maintenance of the open historic character of a storefront and the historic environment.
- Replacing an entire storefront when repair of materials and limited replacement of its parts can be done, will not be undertaken.
- Replace in-kind an entire storefront that is too deteriorated to repair, using the physical and pictorial evidence to guide the new work. If using the same material is not technically or economically feasible, then the HPC may consider a compatible substitute material that conveys the same visual characteristics as the historic such as

finish, texture, profiles, dimensions, function, and details.

- Historic display windows will be preserved and retained along with any historic copper or bronze mullions or other framing features.
- Design a new storefront when the historic storefront is missing (pre-designation), using historical, pictorial, and physical documentation to guide the design, or create a new design that is compatible with the historic building and surrounding district in design, dimensions, scale, massing, details, textures, proportions, locations, finishes, and materials.
- For signage see Sign Guidelines.
- Display, window and door glass is to be clear with a visual light transmittance of no less than 70%.
- Masonry, metal, and wood elements will only be cleaned or paint scraped when absolutely necessary. In such instances the gentlest means possible will be undertaken following the Secretary of Interior Preservation Briefs (see Appendix A) for wood, metal, and masonry cleaning as well as the Guidelines for Exterior Features (pages 43-50).
- Character-defining historic features that remain on a remodeled storefront will be retained and preserved and incorporated into any proposed new design.
- New storefronts will follow historic storefront patterns along the historic streetscape including proportions, scale, display windows, bulkheads, cornices, and recessed entries.
- Historic character-defining entrances and openings will not be removed, altered or enclosed.
- Additional entrance openings on a historic storefront will not be undertaken, unless it would restore a missing feature which is evidenced through historical documentation. Additional openings may be considered on the rear and secondary façades.
- Display windows will not be covered or reduced in size, nor will the spans of glass be broken by additional framing or mullions. Should a large pane of glass be broken and a replacement of the size is not technically feasible, an alternative design will be considered by the HPC.
- OSB, wafer board, rough plywood, MDF, pressed fiber, and other such materials will not be used as finish materials as they often fail to hold up to weather conditions and salt and to match the character of the surrounding historic district.
- Historic character-defining wood or metal awnings, canopies and marquees will be preserved, repaired and retained.
- Fabric awnings may be considered if historically appropriate and compatible with the affected storefront in scale, form and material, if it does not damage or obscure contributing architectural features. Based on finishes and textures, canvas is a historically appropriate material, vinyl does not convey the appropriate finish and appearance.
- Up lighting of awnings will not be permitted.
- Basic awning designs are shed with open ends. Barrel style awnings are typically not appropriate but can be considered depending on the design of the affected building entry.
- Changing the storefront or introducing a new storefront that appears residential rather than commercial will not be undertaken.
- Introducing residential style coach lanterns, mansard roof overhangs, wood shakes, shutters and small-paned windows will not be undertaken unless it can be illustrated to be historically appropriate for the subject building, using pictorial and physical evidence.
- Changing the historic location of a storefront's main entrance will not be undertaken.
- A natural wood appearance (void of paint) is not appropriate.
- The HPC may consider substitute materials when use of in-kind material is found to not be technically or economically feasible (as determined by the HPC).
 - When considering substitute materials, it must match the historic in dimensions, profiles, details, color, pattern, reflectivity, finishes and textures. Where it abuts historic materials, its properties must align with that of the historic to ensure compatible expansion and contraction and avoidance of degradation caused by incompatible materials. substitute material cannot lead to the degradation of surrounding historic materials.

BASIC STOREFRONT DESIGN

These drawings are simply to illustrate a basic historic storefront.
They are not to be taken as a required design for all properties

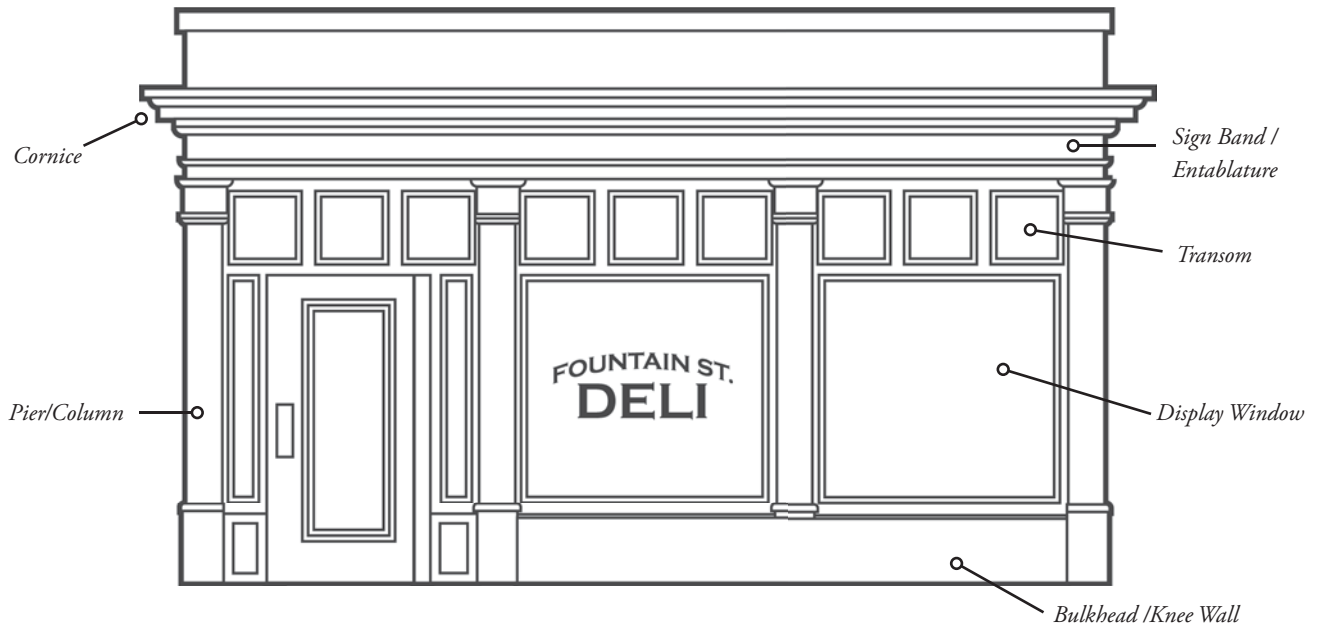

BASIC STOREFRONT

- A basic cornice is constructed with wood, metal or masonry framing and moldings and has a sloping cap to shed water. The cornice spans the top of the storefront, separating it from the upper level.
- Transoms are a design feature that help to break up massive expanses of large sheets of display glass while still allowing the maximum amount of natural light into the store space. Transom windows often contain clear glass, leaded glass or prismatic glass.
- Masonry piers match the upper façade. Wood and metal piers or columns are also typical.
- The storefront is recessed a few inches into the opening.
- Display windows are framed with sills that slope gently down to allow water to drain away from the window sash. Display windows contain clear glass.
- Wood bulkheads typically consist of framing and smooth recessed or raised panels and trim. Occasionally windows will be located within a bulkhead to allow natural light into the basement. Masonry bulkheads are also common.
- The storefront rests on a masonry base to prevent water damage.

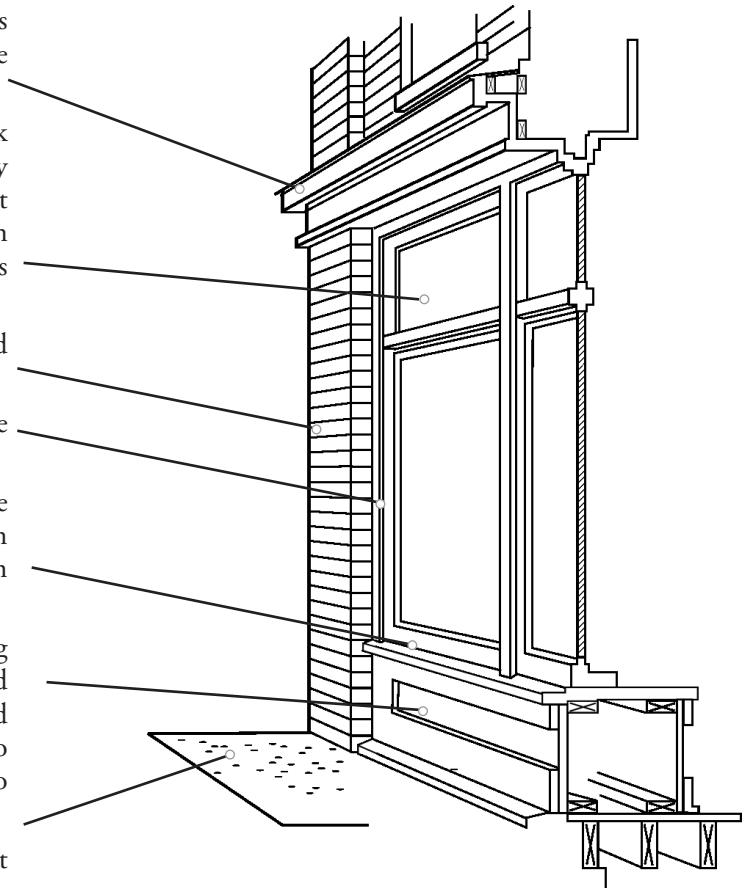



SIGNS

Signs refer to any sign or banner used to display a message intended to advertise or inform, which is secured to or applied to a building or an accessory structure, awnings, or canopies, or which is posted in or on the ground within a site. All proposed signs in a historic district require review and approval by either the HPC or HP staff. In addition, all signs require a City Zoning Permit, and where impacting public property either directly or indirectly, an Encroachment Permit is needed. Signs are reviewed for physical and visual impact to the main structure and surrounding historic district based on size, scale, material, attachment methods, dimensions, location, lighting, and mechanics. They are not reviewed for content.

It should be noted that applicable Zoning Code provisions may further limit the size and location of business signs, in some instances imposing stricter limits than historic district guidelines as such it is important that applicants seeking a sign contact HP staff to discuss options and all Code Restrictions.

There are two basic types of sign placement:

- Affixed Signs – Attached and/or applied to a structure or object.
 - o Sign located within storefront glass area will not exceed 25% of the directly affected glass area.
 - o An affixed sign will be installed to avoid damaging the structure. For example, those affixed to a brick wall will be attached into the mortar joints and not through the brick.
 - o Painted signs may be applied to metal, wood and currently painted masonry surfaces with HP Staff review.

- o Painted signs proposed for non-painted masonry surfaces are generally not appropriate (see masonry and painting guidelines pages 47-49) and as such require HPC review.

- Site Signs – Located on the site such as yard, ground, pole, and A-frame signs
 - o Signs may not be attached to a structure or object. They must be free-standing.
 - o Special attention given to Zoning Code requirements related to placement and traffic safety clear vision requirements.

BASIC SIGN STYLES

- Hanging, projecting/blade, banner signs
- Flat wall mounted signs
- Painted signs on previously painted surfaces
- Awning or canopy signs
- Decals applied to glass or signs hung on inside
- Yard, ground, monument, A-frame and pole signs
- Roof top signs
- Marquee signs

GUIDELINES

- Historic signs that contribute to the architectural character and history of the structure will be retained and preserved. Examples include: historically painted wall or ghost signs (remnants of a historic painted sign), engraved signs and original neon or exposed bulb signs.
- Signs will not obscure, detract from, damage or destroy character-defining historic features and materials.

- Signs will be compatible with the historic character of the structure/building and district in terms of size, scale, design, materials, finish and texture.
- Secondary design elements such as signs will be kept as simple as possible.
- Signs will be compatible in style, size, material, and appearance with the architecture and era of the affected historic building and surrounding historic district.
- Signs proposed for residential areas will be limited in size and scale to be legible at the slow travel speed. They will be small enough as to not dominate or detract from buildings originally designed for non-commercial purposes. They will not impose on pedestrian traffic or disturb the continuity of the streetscape.
- Historically appropriate materials include wood, cast metal, and flat sheet metal. Alternate materials will be considered if they are used in a way that replicates historic materials and designs as it relates to texture, finish, profile, and details.
- Sign lettering, decoration, design or any other elements will be consistent with the scale, design and appearance of the structure to which the sign relates.
- The use of signs, sign features or other types of sign equipment that are inappropriately scaled, or that obscure, damage or destroys character-defining features of the historic building, site or environment will not be undertaken.
- The use of unfinished pressure treated lumber will not be undertaken.
- Signs including all attachment plates, brackets and other elements will not be attached to any historic character-defining features of a building or object.
- Signs proposed to be painted directly onto a masonry surfaces that are not currently painted, is not appropriate.
- Signs proposed to be painted directly onto a masonry surface that is currently painted will be considered if the location, size, scale and design is appropriate for the affected historic structure without detracting from, obscuring or damaging historic character-defining features. In addition, the type of paint to be utilized will conform to preservation standards as not to damage the historic masonry nor trap moisture in the



Appropriate Ground Sign Example



Appropriate Projecting Sign Example

wall causing future damage. Sealants are not permitted. Any cleaning or preparation method must also require review to avoid damaging the historic material.

- Awning signage will be considered for the face of awnings.
- Signs placed on the interior of a building with visibility from the outside through a window have a physical and visual impact on both the historic building and the historic environment. As such they will require review by the HPC or HP staff.
- Signs and any associated element such as light fixtures, brackets and guidewires when installed on masonry walls must be attached through mortar joints.
- Signs that have motion will require HPC review.

SIGN ILLUMINATION

The introduction of lighting to a sign has been undertaken in many ways over the past decades. The oldest method is referred to in this document as external illumination, wherein the light source is independent of the sign structure. Early examples were candles and later gas lanterns placed near the sign. As electricity became more accessible, we began to see the introduction of light fixtures used to illuminate the face of a sign, such as, goose neck lights placed above the sign.

Through the progress of technology electricity began to be placed in the sign allowing for the placement of lights on and eventually within the sign structure itself. This method of lighting is referred to in this document as internal illumination. Early examples include light bulbs placed on the outer face of the sign, crude methods of creating cut outs in the sign face and placing the light bulbs on the interior of the cabinet, and open face neon.

Today common internal illumination includes but is not limited to, neon, flashing lights, back-lit/halo, push through, bulb, electronic, LED, animated, blinking, changeable copy, multi-media, and more.

- External illumination, such as, goose neck lights or discreetly placed spot lighting shall not damage, obscure, detract from or destroy historic character defining features and spatial relationships. Such lighting methods can often be reviewed by HP Staff.
- Internal illumination will require HPC review lest it is a documented historic restoration of a missing historic, character defining, sign which can be reviewed by HP Staff.
- It is not typically appropriate to install an internally illuminated sign on a building or structure that predates the advent of the common use of internally illuminated signs, as they can detract from, overpower and in general fail to be compatible and consistent with the architecture and historic character of the subject building and historic environment. Except as it pertains to restoration or recreation of documented missing historically contributing signs.
- It may be appropriate to install internally illuminated signs on buildings and structures that were erected during an era in which the use of internal illumination was common. In such instances the sign and its lighting must be compatible and consistent with the



58 Monroe Center NW, Circa 1936 (City of Grand Rapids Archives)

architecture and historic character of the subject building/structure and environment. The sign and lighting may not detract, damage, destroy or obscure the historic character and features of the building/structure or the environment.

- o Is the design, scale, finish, and material appropriate and compatible?
- o Is the location appropriate, does it detract or overpower?
- o What is the intensity of the lighting? Does the lighting overpower or detract from the historic building and/or surrounding historic environment?
- For non-contributing buildings, the request for signage with internal illumination will be reviewed for impact to the surrounding historic buildings and environment.
- See National Park Service Preservation Brief #25.

ACCESSIBILITY, HEALTH & SAFETY CONSIDERATIONS

It may be necessary to make modifications or additions to a historic building or site to comply with current health, safety and accessibility codes. Such work must be carefully planned and undertaken so that all needs are met in a manner that does not result in the loss of character-defining features, spatial relationships, or the architectural integrity of the building and district. As part of the planning phase it is important to bring HP Staff into the discussion as soon as possible to assist with the project and to determine avenue for review (HPC or HP Staff).

GUIDELINES

- Ensure that all work meets the requisite A.D.A., barrier free and safety codes in a manner that ensures preservation of the character-defining features of the subject property and surrounding district.
- Minimize the impact on the historic character and materials of the building while still accommodating accessibility, safety, and health needs.
- Locate ramps and other means of access along secondary elevations whenever possible.
- Design ramps and other access means to have simple, non-detracting detailing and finishes.
- Install ramps or other means of access that require changes to the historic character-defining front entry or porch, will not be undertaken unless there are no other means of meeting the required need. In such instances when a feature does need to be removed, it will be retained on site and required to be reinstalled when the ramp or access structure is no longer needed.
- Ramps and other means of access will be temporary and will be required to be removed when no longer needed. The affected area will be restored.
- If a wider entry is required, those located on secondary entries will be utilized rather than the front. The front will only be considered when there are no other options.

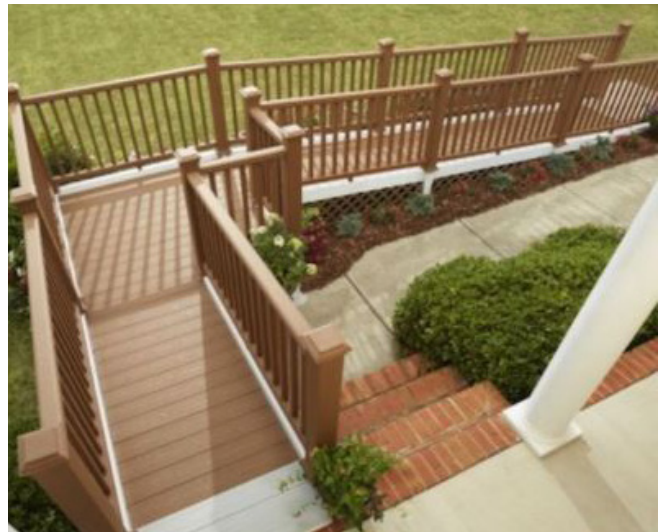

Example of a handicap ramp



A BIG MOVE
Two-block move saves house from demolition

By Morgan Jarema
 The Grand Rapids Press

A house that stood for more than 90 years just outside the boundaries of Heritage Hill became part of the neighborhood Tuesday.

"This returns the lot to residential use," said Jan Earl, director of the Heritage Hill Neighborhood Association. "It couldn't be more perfect. We're ecstatic." The neighborhood association learned this spring that the 1,400-square-foot Craftsman-style house — built in 1912

RELOCATION

Relocating a contributing historic resource located within a historic district or a historically designated local landmark is rarely an acceptable preservation practice, as a critical component to a building's architectural and historical integrity is often based on its location, site, relationships, adjacent structures, and orientations. This is especially true in historic districts where historic properties often combine to create neighborhood character. Removing or relocating a historic resource could jeopardize the historic integrity of the resource, streetscape, and environment. All relocation requests will be reviewed individually on a case-by-case basis utilizing history, context, significance, and integrity of the resource and when applicable historic district.

There are three general types of relocation:

- Moving a building that is currently located outside of a historic district on to a vacant lot located within a historic district. Such relocations can save a historic building from demolition and provide appropriate infill that could help to restore a historic streetscape.
 - o Such requests will be reviewed utilizing the Secretary of the Interior Standards and Guidelines for Rehabilitation and the Local Guidelines for New Construction, Site

CONSIDERATIONS:

- Is the structure threatened with demolition?
- Is relocation the only alternative?
- Is the structure significant enough architecturally or historically to warrant moving it?
- Is the structure sound enough to survive a move?
- Will the introduction of the structure adversely affect the historic character of the district and adjacent structures?
- Will the structure fit into the era of the district; is its style, architectural quality, size and scale compatible with the district?
- Will the move significantly damage contributing historic district site features, such as a tree canopy?

and Environment through a Certificate of Appropriateness review process.

- o Emphasis must be placed on selecting an appropriate location to ensure compatibility with the existing historic context, site, environment, vistas, spatial relationships, architecture, and massing. If the structure is not compatible with the historic environment relocation can result in loss of integrity of the setting and environment.
- Moving a resource that is currently located inside a historic district out of the historic district is akin to demolition as it results in the loss of the resource and affects the integrity of the environment.
 - o Requests that involve contributing resources will be reviewed using the Notice to Proceed Criteria as the project would result in the loss of/removal of the resource from the Historic District.
 - o Requests to remove non-contributing resource from the district will follow the Secretary of the Interior Standards and Guidelines for Rehabilitation as well as Local Guidelines for Site, Environment and when applicable New Construction.
- Moving a resource that is currently located inside a historic district to a vacant lot located within the district.
 - o Requests involving contributing resources will typically be reviewed using the Notice to Proceed Criteria but can, under certain circumstances qualify for a CoA through use of Secretary of the Interior Standards and Guidelines for Rehabilitation and Local Guidelines.
 - o Requests involving non-contributing resources will follow the Secretary of the Interior Standards and Guidelines for Rehabilitation as well as Local Guidelines for Site, Environment and New Construction.

AVENUES OF REVIEW

There are two avenues for review, a Certificate of Appropriateness, and a Notice to Proceed. To determine the proper course of action these questions need addressing:

- Is the resource contributing to a historic district?

- Is the current location an important character defining feature of the resource?
- Is the current location an important character defining feature of the district?
- What role does the site play in the resource and/or districts significance?

NOTICE TO PROCEED

Most relocation requests that affect a contributing historic resource will have a significant negative impact on the historic integrity of both the resource and the surrounding historic environment and thus fail to qualify for a Certificate of Appropriateness. However, moving a historic resource is preferred over demolition and may be the only viable option to save an important resource and as such relocation can be considered in limited circumstances through a Notice to Proceed, when all other avenues for retaining the resource in its historic location have been exhausted.

Example: A historic contributing resource is in the way of water treatment plant that is greatly needed by the community to address Lead concerns. All other possible locations for this facility have been vetted and exhausted and given the nature of the facility and the underground work needed, incorporating the resource into the project is not possible. In this instance the request may meet burden of proof to relocate the resource through issuance of a Notice to Proceed under Criteria B: that it is in the way of a major improvement project of substantial benefit to the community.

CERTIFICATE OF APPROPRIATENESS

Rare instances may occur where a request to relocate a resource may comply with the Secretary of the Interior Standards and Guidelines for Rehabilitation and Local Guidelines. State Enabling Act PA 169 includes the term “moving” in the definition of “work” and as such “moving” a resource, under the correct circumstances and conditions could be an appropriate action.

Example: Request to relocate a historic resource which was designated solely for the role it played in history or as part of an important movement and not for its architecture, location, site, or relationship to other buildings. As this resources significance is associated solely with historical events the inside of the resource holds more significance to the historic context of the designation than the site itself. In this instance relocation of the resource may have minimal impact to the historic significance and integrity of the resource and thus qualify for a Certificate of Appropriateness.

CONSIDERATIONS:

- Compelling reason for relocation.
 - o Notice to Proceed Criteria
- (a) The resource constitutes a hazard to the safety of the public or to the structure's occupants.
- (b) The resource is a deterrent to a major improvement program that will be substantial benefit to the community and the applicant proposing the work has obtained all necessary planning and zoning approvals, financing, and environmental clearances.
- (c) Retaining the resource will cause undue financial hardship to the owner when a governmental action, an act of God, or other events beyond the owner's control created the hardship, and all feasible alternatives to eliminate the financial hardship, which may include offering the resource for sale at its fair market value or moving the resource to a vacant site within the historic district, have been attempted and exhausted by the owner.
- (d) Retaining the resource is not in the interest of most of the community.
 - o Certificate of Appropriateness Historic Significance, Guidelines and Standards.
- Is the current site the original or historic site for the resource or has it been relocated in the past?
- What is the significance of the resource? What makes it significant on its own or contributing to a historic district? A resource can be significant based on its connection to historic events and patterns of history, its association with historic figures, its embodiment of construction/architecture and/or its likelihood to yield important history. Does the current site contribute to the historic integrity, context, significance, or history of the resource and/or when applicable the historic district?
- Does the current site hold historical integrity? Has it been significantly altered?
- Reasonable alternatives have been examined to mitigate the threat to the historic resource, in lieu of relocation such as:
 - o Modifications to proposed project affecting the historic structure to avoid its impact on the location of the historic resource.
 - o Incorporation of historic resource, in its entirety, into the proposed project which would affect the location of the historic resource.
- Can the resource be practically preserved on its current site?
- Can the resource endure the move? What are the potential physical effects of movement on the structure? Structural Engineering report(s) will be required with any relocation application.
- Prior to relocation the resource, contributing out buildings and site will be documented through photographs and a site plan created with four directional cardinal points noted, and the relationships to outbuildings and other site and landscape features noted.
- Resources should be relocated in one-piece; however, consideration may be given should porches, chimneys or small additions need be separated for the move and then reattached to the main building at the new site. Noting any removed elements must be clearly marked with each unit's orientation, i.e., front and back, and its location on the resource. Such information will also be marked on a plan and elevation graphics. A secure location for storage of said components will be provided.
- Routes between the historic location and the new proposed site must be suitable for transporting a resource.
- Ensure professional building mover is utilized to undertake the move and that the move is adequately covered by insurance for all phases of relocation.
- Provide protection by bracing or covering fragile features such as chimneys, stucco, plaster work, windows, and decorative trim.
- All features either original or later additions that contribute to the historic character of the resource will be retained.
- Outbuildings that are important to the historic character of the resource and/or environment will be moved to the new site with the main resource.

- Make appropriate repairs to sill plates and floor joists while the resource is on temporary cribbing and these features are accessible and visible.
- New foundation shall match the historic foundation in height, design and materials or be compatible with the historic character of the resource taking into consideration the historic character of the new site and its environment.
- What are the effects of the movement on the proposed new site?
- Are the proposed plans for the vacated site appropriate and compatible with all other guidelines and standards?
- Is the proposed location compatible with the cultural, historical, or architectural character of the resource being moved? Is the resource compatible with its new surroundings in terms of architectural style, massing (height, width, and depth), features and materials?
- New site should provide a similar setting to the existing.
- Site the resource to retain its original directional orientation when possible. Recognizing and replicating as much as possible any strong visual relationships it may have had to landscapes or other features such as roads.
- Ensure compatibility with the new site to not cause negative effects to the historic character of the new location and when applicable, surrounding historic district, thus diminishing its integrity.
- Retain the historic relationship between buildings and the landscape.
- Allow adequate time for the historic resource to settle on the new foundation before repairing finishes or chimney features.
- Place historic outbuildings at the new site at the proper location and distance from the main resource based taking into consideration historic orientation prior to relocation as well as historic character of the new location and environment.

BE ADVISED (POST APPROVAL)

- Once the structure has been secured and raised off its foundation the structure must be fully assessed by a licensed structural engineer to assure it is structurally sound to continue with the move. Upon completion of report and before relocation continues a copy of the report must be submitted to HP Staff.
- Should it be found that the structure, upon lifting, cannot withstand further disturbance the structure must be placed back atop its historic foundation or approved new foundation should the historic foundation no longer be stable. Alternatively, the structure will be stabilized for temporary suspension while the applicant returns to the HPC.
- Should it be determined after the structure is lifted and moved off the site that it cannot be relocated to the approved site the structure must be moved back to its historic location and placed atop its historic foundation or approved new foundation should the historic foundation no longer be stable. Alternatively, the structure will be secured and stabilized for temporary suspension at its historic site while the applicant returns to the HPC.



DEMOLITION

Demolition of a historic structure creates a permanent change in and loss to the district, reducing the historic and architectural significance. As such the utmost care and consideration is given to these requests. All demolition requests require the review of the HPC. Such requests are reviewed using the four criteria listed below. It is the responsibility of the applicants seeking permission to demolish a contributing historic structure to supply sufficient evidence to prove their request meets a minimum of one of the four criteria. The final determination as to whether or not the burden of proof has been met and that demolition is necessary is the onus of the HPC, per State Enabling Act PA 169, Local Ordinance Chapter 68 and Historic Preservation Procedures and Bylaws pertaining to a Notice to Proceed.

CRITERIA:

- (a) The resource constitutes a hazard to the safety of the public or to the structure's occupants.
- (b) The resource is a deterrent to a major improvement program that will be a substantial benefit to the community and the applicant proposing the work has obtained all necessary planning and zoning approvals, financing, and environmental clearances.
- (c) Retaining the resource will cause undue financial hardship to the owner when a governmental action, an act of God, or other events beyond the owner's control created

the hardship, and all feasible alternatives to eliminate the financial hardship, which may include offering the property for sale at its fair market value or moving the resource to a vacant site within the historic district, have been attempted and exhausted by the owner.

- (d) Retaining the resource is not in the interest of the majority of the community.

ALTERNATIVES TO DEMOLITION

- Redesign the project to avoid any impact to the structure or setting.
- Find a different location better suited for the project.
- Incorporate the structure into the overall design of the project.
- Convert the structure into another use.
- Relocate the structure on the current property.
- Relocate the structure to another property within the same historic district.
- If a building is not contributing to the district and its removal will not result in negative impact to the site, environment, rhythms, special relationships and streetscape its removal may be considered.

HISTORIC PRESERVATION AND SUSTAINABILITY

Preservation of historic buildings is a sustainable practice as it promotes continued use and maintenance of our historic building stock over unnecessary replacement, additions to landfills, and use of more energy and resources. Recognizing the connection between historic preservation and sustainability and the desire of property owners to have energy-efficient dwellings, the design guidelines are designed to balance flexibility with preserving the historic character and materials of individual buildings and the community as a whole. For additional information and references see National Park Service Guidelines for Cultural Landscapes and Secretary of the Interior Standards and Guidelines for Rehabilitation.

SUSTAINABLE MATERIALS

Historic building construction embraces durable traditional materials such as old growth lumber, brick, and stone, which last for centuries if properly maintained, whereas many contemporary manufactured materials are not only unsustainable in their production but have a comparatively shorter lifespan. Some contemporary materials need to be replaced more often, causing the use of more energy and more deposits into landfills.

EMBODIED ENERGY

Historic preservation as a sustainable practice retains the “embodied” or “already present” energy within the existing building stock. From the manufacture of goods, to the transportation of those goods, to the project site, to the physical labor needed for construction, buildings represent large expenditures of energy. Preserving a building and maintaining its features retains this embodied energy and minimizes the need for additional energy to produce new materials. Even when designed to be as sustainable as possible, new construction can take decades of incremental savings to recoup the embodied energy represented in the demolished building. In addition, it takes years for new construction to offset the substantial material waste associated with demolition and disposal of the materials of the former building. Based on this reasoning, the replacement of historic buildings with even sustainable architecture, makes little financial and environmental sense.

SUSTAINABLE CONSIDERATIONS IN THE PROJECT PLANNING PROCESS

Consider goals for energy savings at the beginning of a project is particularly important in making sure that the

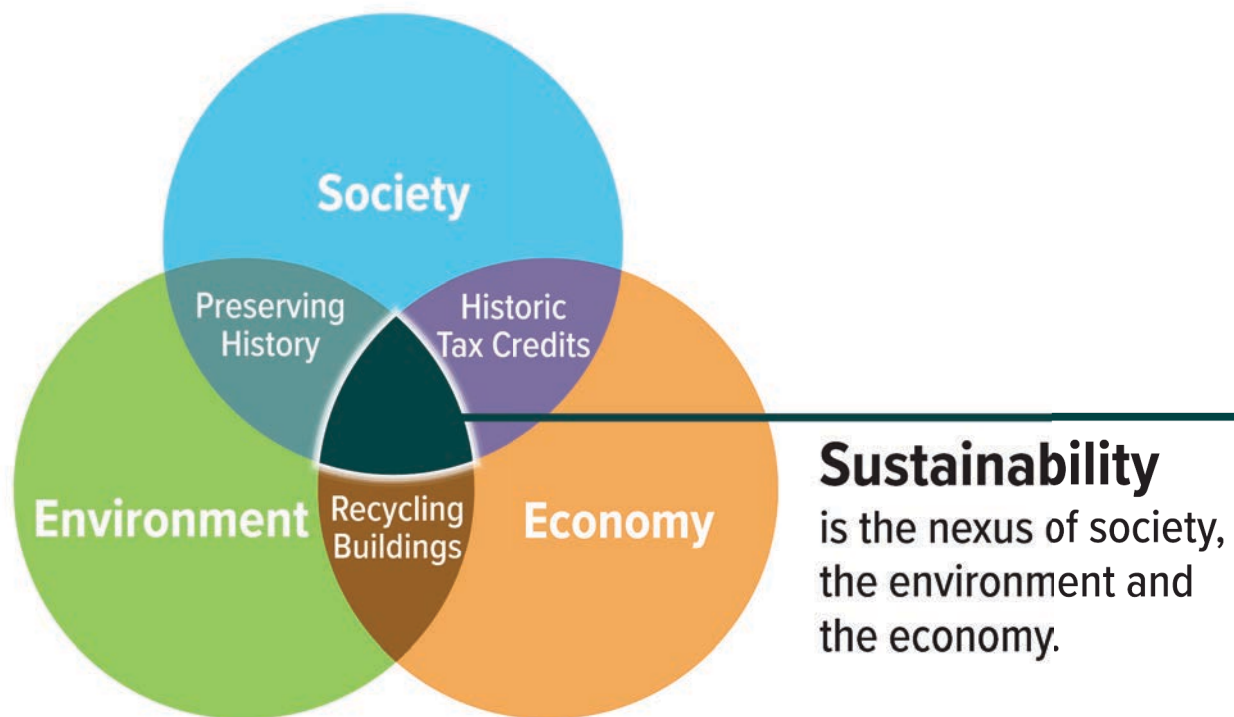

project balances efficiency with limiting any ill-effects on the historic character and features of a building. In other words, energy-efficient approaches should not be afterthoughts in planning the project. It is useful to have an expert conduct an energy audit, which is a comprehensive and systematic overview of how energy is used and distributed in the building. This can be a tremendously useful tool in assessing which upgrades will provide the most benefit.

EMBRACE REPAIR AND REUSE OF HISTORIC MATERIALS AS A PRIORITY

Preserving existing building fabric in sound condition should be a priority not only to retain historic character but also to limit the need to expend energy in the production of new materials (which are often not recyclable). Continued use of building fabric begins with routine maintenance and timely repair of materials to minimize significant deterioration. During a repair or renovation project, historic building material should be protected to avoid accidental damage that may cause a need for replacement. Temporary removal of historic materials to make repairs or renovate should be avoided, but if it becomes necessary, materials should be removed with enough care to allow reinstallation.

TAKE ADVANTAGE OF THE GREEN FEATURES OF A HISTORIC BUILDING

Many historic buildings use design features that promote natural means of energy efficiency. When developing a project and incorporating “green” design features, a property owner should first gain an understanding of the existing sustainable qualities of their building. Doing so will help to ensure that the effectiveness of these features will not be reduced and that energy and money are not being spent on something the building already provides. For example, retain the innate energy efficiency and savings provided by operable features such as windows, shutters, chimneys and transoms by maintaining their operation.

INCORPORATE SUSTAINABLE MEASURES IN CONSIDERATION OF A BUILDING’S CHARACTER

While the design guidelines allow for appropriate sustainable measures such as solar panels, storm windows and rainwater collection systems, it is important that any added features do not detract from or harm the historic character, features and materials, of the building or the district.



YOUR HISTORIC STRUCTURE MAY ALREADY BE A GREEN BUILDING

By their design most historic buildings already contain numerous “green” features that promote energy efficiency. In considering the sustainable features of your historic building, look for the following:

- Substantial tree canopy that provides natural shade and cooling.
- Operable, double-hung windows that allow cool air to flow in and the warm air to pass out. Both the upper and lower sashes originally operated to allow cool air in through the bottom and push hot air out through the top sash.
- Windows arranged to take advantage of natural lighting, as well as passive heating in the winter.
- Deep-set porches that moderate temperature fluctuations between interior and exterior spaces.
- Deep eaves that provide for seasonal shade and water removal.
- Steeply-pitched roofs that allow heat to pass upward away from the living space, while also diverting rainwater.
- Operable shutters or awnings used to block solar heat gain.
- Window and door arrangements, including transoms, that allow for cross-ventilation.
- Heavy masonry materials with natural thermal mass properties.
- Chimneys that allow non-mechanical heating.
- High ceilings that facilitate movement of air.

APPENDICES

APPENDIX A

RESOURCES AND TECHNICAL INFORMATION

National Park Service Technical Preservation Briefs provide a set of user-friendly guidance documents on preserving, rehabilitating, and restoring historic buildings and individual components. Preservation Briefs, such as those listed below and more, the Secretary of the Interior Standards and Guidelines for Rehabilitation, and the National Park Service Treatment of Cultural Landscapes are available at <http://www.nps.gov/tps/how-to-preserve/briefs.htm>.

- 1 The Cleaning and Waterproof Coating of Masonry Buildings.
- 2 Repointing Mortar Joints in Historic Brick Buildings.
- 3 Conserving Energy in Historic Buildings.
- 4 Roofing for Historic Buildings (also see 19, 29, 30).
- 5 The Preservation of Historic Adobe Buildings.
- 6 Dangers of Abrasive Cleaning to Historic Buildings.
- 7 The Preservation of Historic Glazed Architectural terra cotta.
- 8 Aluminum and Vinyl Sidings on Historic Buildings (also see 16).
- 9 The Repair of Historic Wooden Windows.
- 10 Exterior Paint Problems on Historic Woodwork.
- 11 Rehabilitating Historic Storefronts.
- 12 The Preservation of Historic Pigmented Structural Glass.
- 13 The Repair and Thermal Upgrading of Historic Steel Windows.
- 14 New Exterior Additions to Historic Building Exteriors (also see 8).
- 15 Preservation of Historic Concrete: Problems and General Approaches.
- 16 The Use of Substitute Materials on Historic Building Exteriors (also see 8).
- 17 Architectural Character: Visual Aspects of Historic Buildings - Aid to Preserving Character.
- 18 Rehabilitating Interiors in Historic Buildings.
- 19 The Repair and Replacement of Historic Wooden Shingle Roofs.
- 20 The Preservation of Historic Barns.
- 21 Repairing Historic Flat Plaster Walls and Ceilings.

RESOURCES AND TECHNICAL INFORMATION (CONTINUED)

- 22 The Preservation and Repair of Historic Stucco.
- 23 Preserving Historic Ornamental Plaster.
- 24 Heating, Ventilating, Cooling Historic Building: Problems and Recommended Approaches.
- 25 The Preservation of Historic Signs.
- 26 The Preservation and Repair of Architectural Cast Iron.
- 27 The Maintenance and Repair of Architectural Cast Iron.
- 28 Painting Historic Interiors.
- 29 The Repair, Replacement and Maintenance of Historic Slate Roofs.
- 30 The Preservation and Repair of Historic Clay Tile Roofs.
- 31 Mothballing Historic Buildings.
- 32 Making Historic Properties Accessible.
- 33 The Preservation and Repair of Historic Stained and Leaded Glass.
- 34 Applied Decoration for Historic Interiors: Preserving Composition Ornament.
- 35 Understanding Old Buildings: The Process of architectural Investigation.
- 36 Protecting Cultural Landscapes: Planning, Treatment and Management.
- 37 Appropriate Methods for Reducing Lead-Paint Hazards in Historic Housing.
- 38 Removing Graffiti from Historic Masonry.
- 39 Holding the Line – Controlling Unwanted Moisture in Historic Buildings.
- 40 Preserving Historic Ceramic Tile Floors.
- 41 The Seismic Retrofitting of Historic Buildings.
- 42 The Maintenance, Repair and Replacement of Historic Cast Stone.
- 43 The Preparation and Use of Historic Structures Report.
- 44 The Use of Awnings on Historic Buildings.
- 45 Preserving Wood Porches.
- 46 The Preservation and Reuse of Historic Gas Stations.
- 47 Maintaining the Exterior of Small and Medium Size Historic Buildings

APPENDIX B

NEW CONSTRUCTION CHECKLIST

The following checklist may be used by applicants to help create a complete application packet when applying for new construction. The checklist is not required.

SITE

Walkways and Driveways

- Location
- Dimensions
- Materials/Finish

Fences

- Location
- Scale/Height
- Materials/Details
- Meet zoning requirements

Mechanical and Utilities Screening

- Location
- Visibility from public street right of way

BUILDINGS

Building Placement

- Distance from street (setback)
- Oriented to primary street
- Respects existing pattern of spacing between buildings

Size

- Massing relates to existing buildings
- Complexity of form is compatible with surrounding buildings
- Height is within 10% of adjacent buildings
- Width is within 10% of surrounding buildings

Roof

- Compatible pitch and form
- Materials are compatible with historic precedents
- Chimneys, dormers and other features are of appropriate scale

Windows and Doors

- Compatible ratio, spacing and proportions
- Window material and casing compatible with historic precedents
- Door style and finish are compatible with historic precedents
- True divided light or simulated divided light
- Storm windows and doors painted and conform to openings and window/door divisions
- Shutters (if included) are scaled to the opening and include hinge hardware

Porches

- Compatible to the scale and style of surrounding houses
- Design respects materials, proportions and placement of surrounding houses

Materials and Details

- Traditional materials
- Alternative materials that adequately simulate the authentic material

APPENDIX C

BASIC ARCHITECTURAL FEATURE EXAMPLES

These images are designed to be used as reference only – They are not recommendations and are not appropriate for all applications – Nor shall they be considered as automatically approvable.

Roofs

Included are images illustrating various roof pitches and common roof styles found on historic buildings.

Roof Pitch

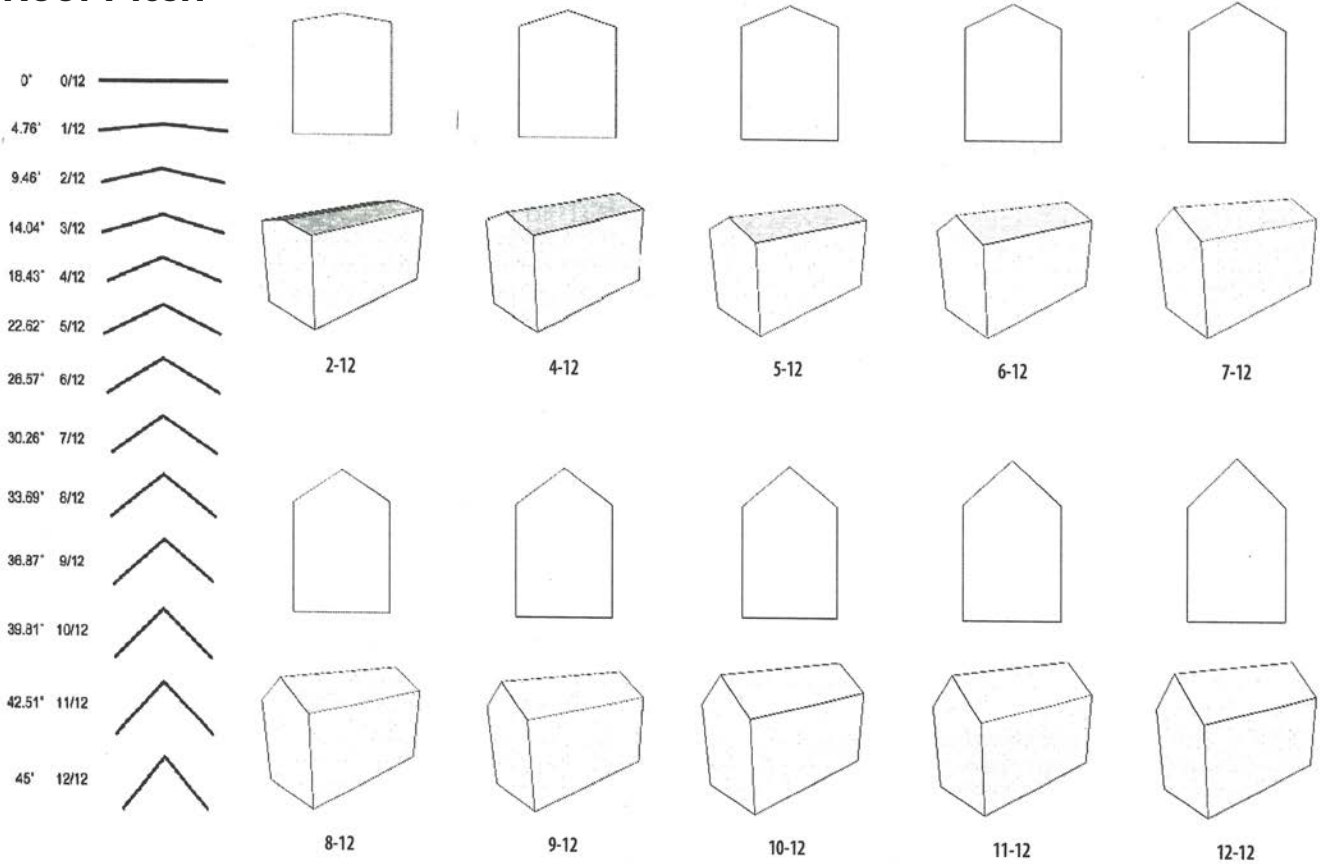

Roof Types

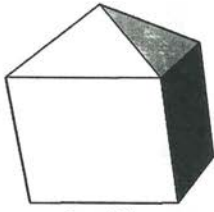

Pyramidal

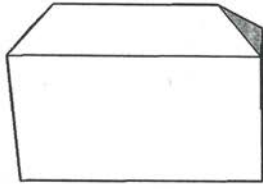

Hipped

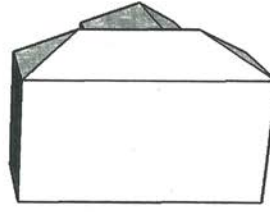

Cross Hipped

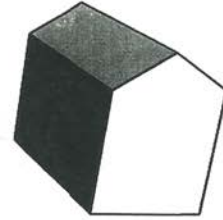

Front Gable

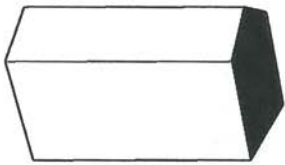

Side Gable

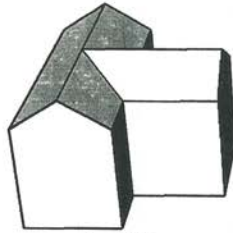

Cross Gable



Gambrel

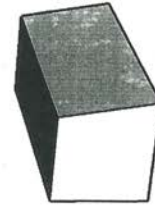

Shed

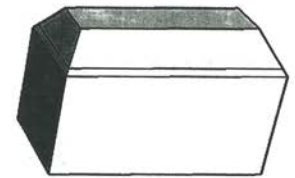

Mansard

Roof Types - Aerial View



Pyramidal

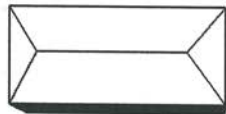

Hipped

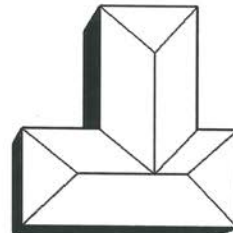

Cross Hipped



Front Gable

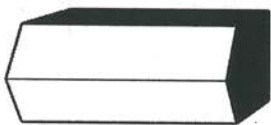

Side Gable

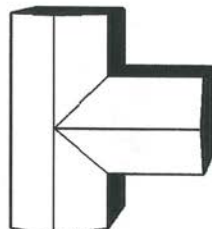

Cross Gable

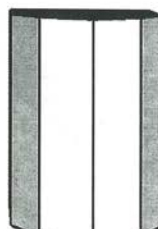

Gambrel



Shed

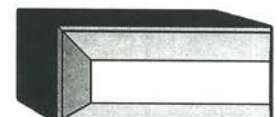

Mansard

Dormers

Included is an image illustrating common dormer shapes.

Examples of dormer shapes

Gable

Hip

Shed

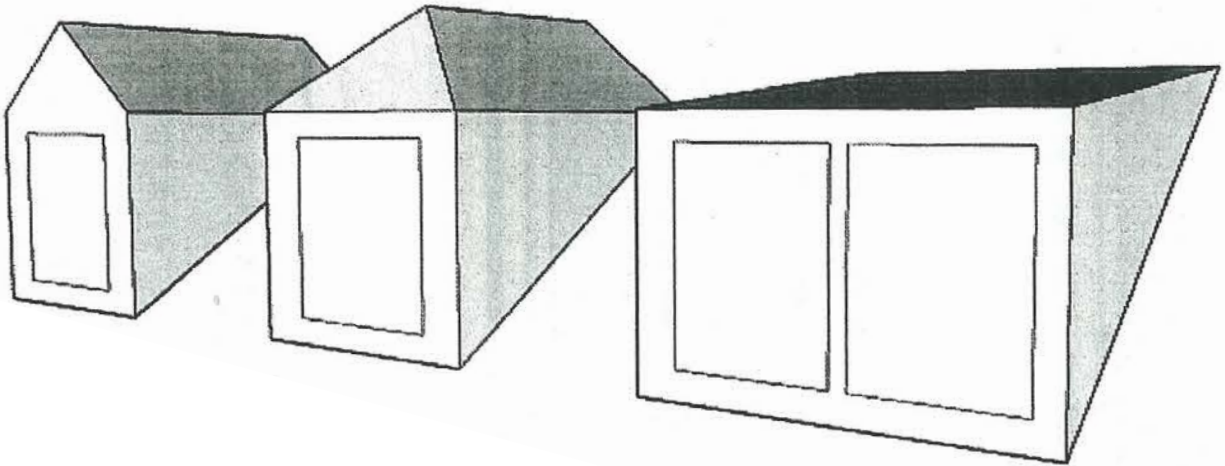

Examples of dormer additions

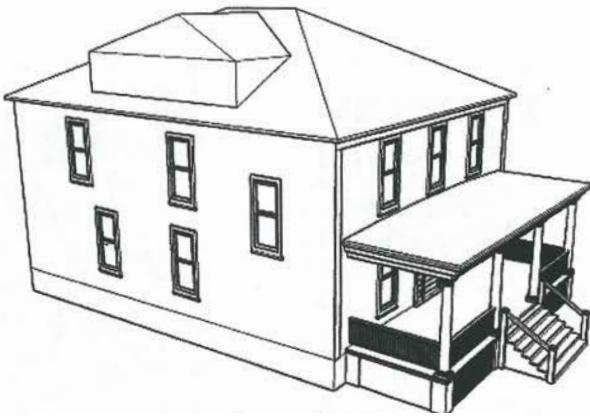

Inappropriate scale

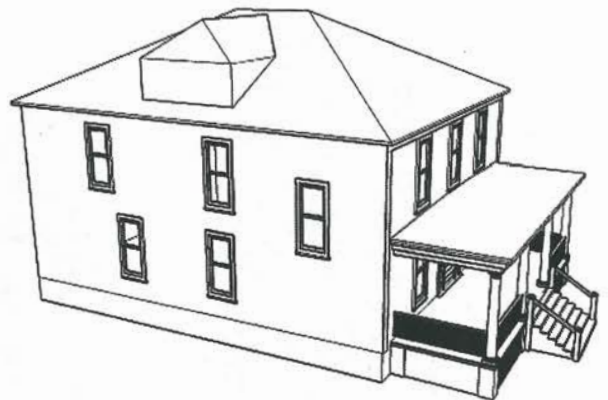

Appropriate scale

Windows

Included images of basic window styles and a detailed image of the make-up of a double-hung window. Many of these features are often also found on all other window designs and operations including casement, awning, hopper and fixed

Double Hung

Can be found in nearly all architectural styles and eras

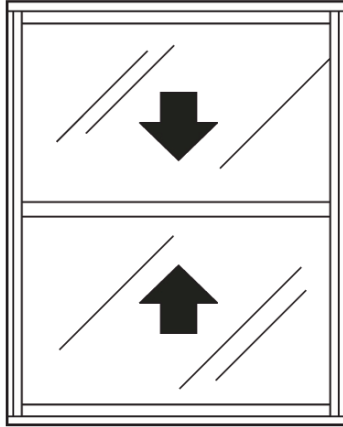

Casement Sash

Commonly found in Tudor, Renaissance, Revivals and, Craftsman architecture

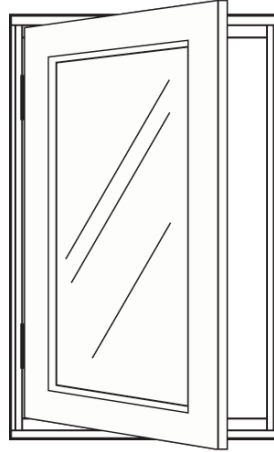

Fixed

Commonly found in International and Contemporary architecture

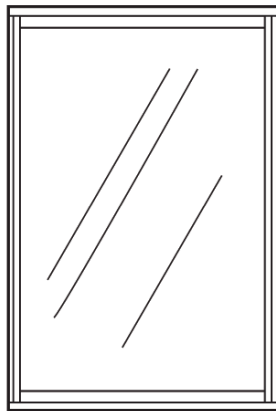

Vertical Pivot

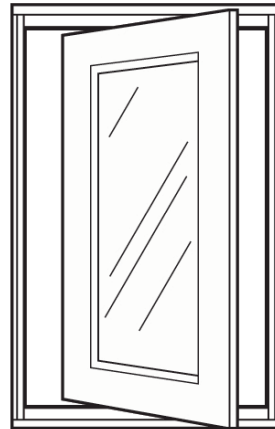

Louvre

Commonly found in Minimal Traditional and Ranch architecture.

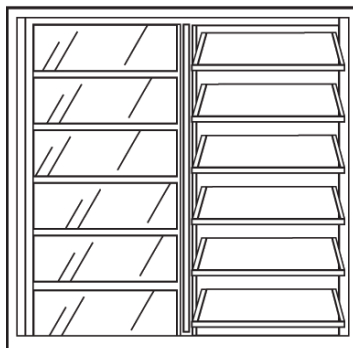

Horizontal Sliding

Commonly found in Minimal Traditional, Ranch and, Contemporary architecture

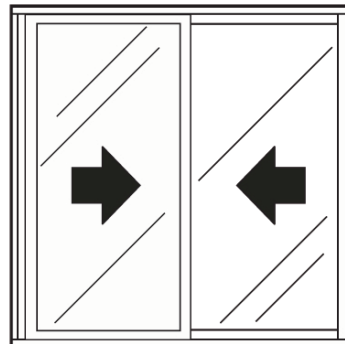

Doors

Included are images illustrating various common door designs and their associated names.

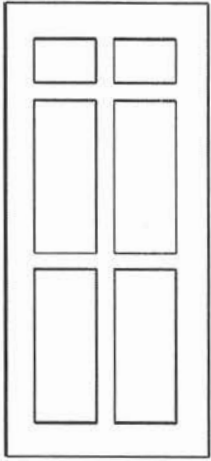

6-Panel Vertical

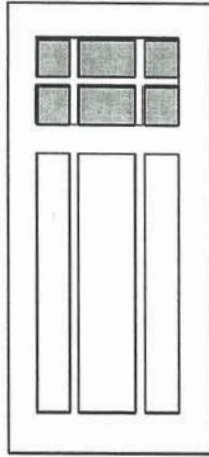

Craftsman 6-Lite
& Panel

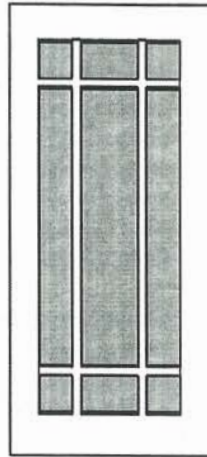

Craftsman 9-Lite

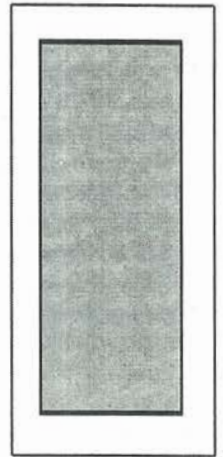

Full-Lite

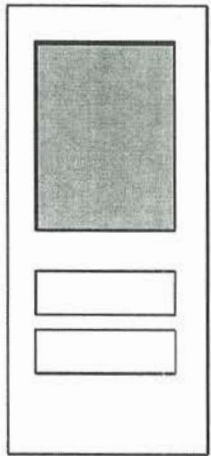

Half-Lite Double
Panel Horizontal



Half-Lite Double
Panel

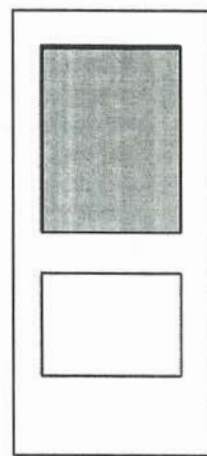

Half-Lite Single
Panel

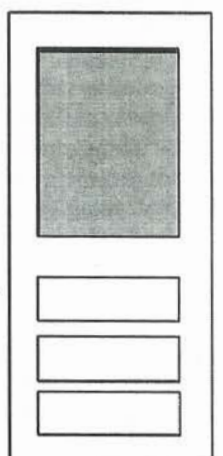

Half-Lite Triple Panel

Columns

Included are images illustrating basic Greek Order columns.



Corinthian



Ionic

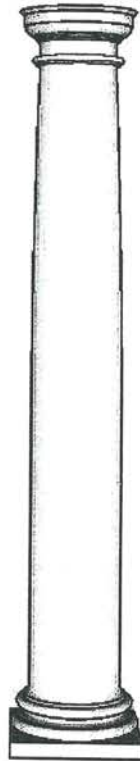

Tuscan

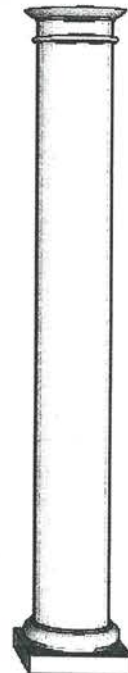

Roman Doric

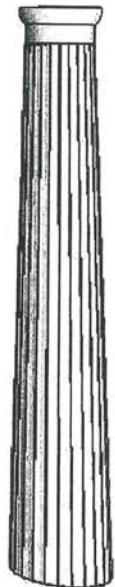

Greek Doric

APPENDIX D

HISTORIC BUILDINGS AND LEAD PAINT

Drastic measures to eliminate lead paint from your historic house or building need not be taken. Lead paint is only a hazard if it is unstable, so the mere presence of lead paint is not reason to destroy the historic fabric of your structure. There are safe and cost-effective ways to remove or work around lead paint, from simple housekeeping by addressing dust to stripping paint.

While only a professional can analyze paint to determine if lead is present it is a fair assumption that if you own or live in a building built before 1978 that you can anticipate the existence of some lead paint and as such should educate yourself about smart lead management. While lead paint can be removed from siding, window jambs, window sashes and trim safely through lead safe practices the simple management of things like dust and paint chips will go the furthest, as it's these types of unstable lead paint that can create a potential poisoning hazard. Focus should be on eliminating the dust from lead paint.

Manage the Lead Paint in your House or Building

You can manage the lead paint in your historic house or building by using these practices:

- Dust your house weekly to remove lead dust.
- Use an EPA-approved HEPA vacuum to vacuum your house or building. These vacuums take in the dust but do not release a significant amount of dust back into the air.
- Eliminate any painted surfaces that rub together and generate lead dust through the use of things like metal jamb liners for windows or follow EPA requirements in stripping impact surfaces such as door edges and door jambs, window sashes and window jambs, etc.
- Never dry-scrape old paint, mist the wood with water first to prevent the spread of lead dust.
- Do not remove old paint with a blower-type heat gun, which heats to a dangerously high temperature. Lead paint becomes toxic vapor at about 650 degrees Fahrenheit. Instead, use an infrared paint removal tool. Infrared tools will not heat the paint above 600 degrees as such they are approved by the EPA to be safe for removing lead paint.

Hiring a Contractor

The EPA Lead Renovation, Repair and Painting Rule requires that firms or contractors performing renovation, repair, and painting projects that disturb lead-based paint in a structure built before 1978 be certified by the EPA. Using these companies will greatly reduce any potential risk from lead contamination. When interviewing potential contractors ask them how they address lead issues.

Doing it Yourself

Homeowners doing work on their own homes (where they reside) are not subject to the regulations noted above, however, it is highly recommended that anyone removing lead paint follow the EPA regulations for the safety of themselves and those around them.

NOTE: The information presented here is not intended to provide comprehensive technical advice or instructions on living with and working with lead. Any information contained or referenced is meant to provide a basic introduction with direction to follow and further research through the EPA.

APPENDIX E

HISTORIC BUILDINGS STYLES



Greek Revival
c. 1825-1860

Noted for porches, low pitched roofs, classical detailing, temple facades, Greek order columns, sidelights, transoms and multi-paned windows.



Italianate Revival
c. 1840-1890

Noted for low pitch hip roof, wide eaves, paired brackets, squared cupolas, architrave porches, rectangular massing, vertical proportions, tall narrow windows and, heavy moldings.

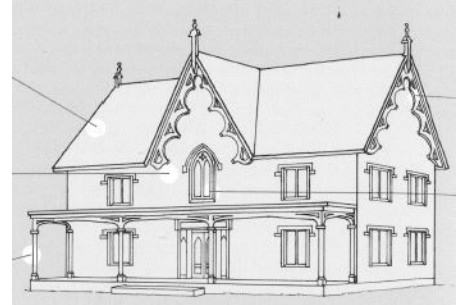

Gothic Revival
c. 1840-1880

Noted for steeply pitched roofs, pointed windows, decorative tracery, leaded glass, clover shaped windows, oriel windows and ornate verge/barge trim.



Stick Style
c. 1860-1890

Noted for steeply pitched roofs, overhanging eaves, ornamental trusses, decorative support braces and, stick decoration.



Queen Anne
c. 1870-1910

Noted for an irregular plan, bay windows, towers, turrets, porches, balconies, stained glass, finials, decorative trim, brackets, spindles, shingles/shakes and, belt course trim.



Colonial Revival
c. 1880-1940

Noted for multi-paned windows, palladian windows, rectangular massing, dormers, pillars, columns, porticos and, paneled central doors.



Neo-Classical Revival
c. 1895-1950

Noted for full height porches supported by classical columns, hip and gable roofs, symmetrical facades, multi-light windows, and classical details such as dentils and pediments.



Tudor Revival
c. 1890-1940

Noted for steep pitched roof, gable roofs, stucco, half-timber, casement windows, leaded glass, tall narrow windows typically ganged, and exterior chimneys.



Four Square
c. 1890-1930

Noted for low pitch hip roofs, dormers, square footprint, porches and symmetrical facades.



Craftsman
c. 1905-1940

Noted for low pitched roof, wide eaves, large eave brackets or beams, full width porches, brick, stucco, leaded and stained glass, ribbon windows, casement windows and, small scale.



Prairie
c. 1900-1920

Noted for low pitched hip roofs, wide eaves, horizontally ganged windows, masonry porches, masonry exteriors (stucco and brick), massive square porch supports.

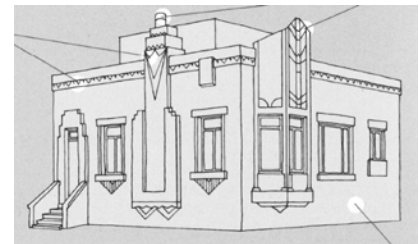

Art Deco
c. 1920-1940

Noted for flat roofs, smooth exterior finishes such as tile and stucco, horizontal lines, zigzags, chevron, and geometric details, terraces and metal work.



Minimal Traditional
c. 1935-1950

Noted for a side gable roof, wide clapboard siding or brick siding, colonial features, one and a half stories, multi-pane windows, central door, shutters, no porch.

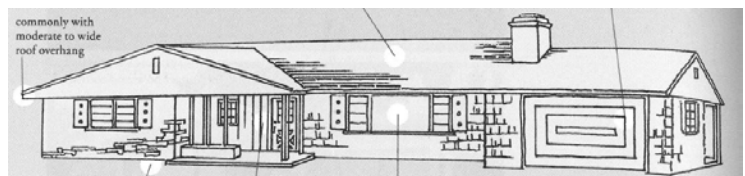

Ranch
c. 1935-1975

Noted for broad one-story shape, built low to the ground, low pitch roofs, wide eaves, sheltered off-center entry, large picture window, asymmetry, attached garage and attached planters.

APPENDIX F

TERMINOLOGY GUIDE

A

Aluminum Siding:

Sheets of exterior wall covering fabricated from aluminum to resemble wood siding. Developed in the 1940's with highest point of popularity between the 1950's and 1960's.

Appropriate:

Suitable for, or compatible with, a property based on accepted standards and techniques for historic preservation.

Arch:

A curved and sometimes pointed structural member used to span an opening.

Architrave:

The lower part of a classical entablature, resting directly on the capital of a column, the molding around a window or door.

Asphalt Shingle:

A shingle manufactured from saturated roofing felts, rag, asbestos or fiberglass coated with asphalt and finished with mineral granules on the side exposed to the weather.

Awning:

A roof-like cover of canvas or plastic over a window or door to provide protection from the sun, wind or rain.

B

Balustrade:

A series of balusters or upright connected on top by a handrail and sometimes on the bottom by a bottom rail to provide an ornamental and protective barrier along the edge of a stair, roof, balcony or porch. (Rail with vertical spindles).

Bargeboard/Verge Board:

A sometimes richly ornamented board placed on the verge (incline) of the gable (roof) to conceal the ends of rafters; typically seen in the styles of the 19th century.

Battered Column:

A column that is thicker at the bottom than at the top.

Bay:

(1) An opening or division along a face of a building; for example, a wall with a door flanked by two windows is three bays wide. (2) The space between principle structural members, as in a timber frame, the space between posts. (3) A projection from the façade of a building, such as a bay window.

Beveled Glass:

Glass panels whose edges are ground and polished at a slight angle to form a beveled border; used for entrance doors and ornamental work.

Board and Batten:

Siding fashioned of boards set vertically and covered where the edges join by narrow strips called battens.

Brick Bond:

The pattern in which masonry, particularly brickwork, is laid to tie together the thickness of the wall.

Bracket:

Projecting support members under eaves or other overhangs; plain or decorated. Often called console brackets, they are characteristic of many styles, most notably Italianate.

Bulkhead:

The area between the display window and the ground on the front façade of a commercial storefront.

C

Capital:

The top member of a column, usually decorated or molded. Each classical order – Doric, Ionic, Corinthian, Composite – has its characteristic capital.

Casement:

A window with sash hung vertically, which opens inward or outward.

Casing:

The finished visible framework around a door or window.

Certificate of Appropriateness/Historic District Work Permit:

When an owner or their representative within a historic district wants to make changes to or repairs to the exterior of structures or site, a Certificate of Appropriateness (CoA)/Historic District Work Permit, is needed from the HPC and or HP Staff before work can commence. The CoA grants permission for the proposed work that is compatible with the adopted design guidelines and Secretary of Interior Standards.

Chamfer:

A beveled edge on a corner of a post, wall, etc. May take the form of a flat surface, or a more elaborately molded surface. Edges so beveled are said to be chamfered.

Character-Defining Features:

Individual physical elements of any structure, site, street, object, or district which contributes to the overall historic or architectural character, and for which it is recognized as historically or architecturally significant.

Clapboard:

Long horizontal boards with one edge thicker than the other, overlapping to cover the outer walls of framed structures; also known as weatherboard.

Composite Order:

A classical order that incorporates the large volutes (spirals) of the Ionic Capital with the lush foliage of the Corinthian Capital.

Historic/Contributing Resource and Non-Historic/Non-Contributing Resource:**• Historic/Contributing:**

Means a publicly or privately owned building, structure, site, object, feature or open space that is significant in the history, architecture, archaeology, engineering, or culture of this state or a community within this state, or of the United States.

• Non-Historic/Non-Contributing:

Means a publicly or privately owned building, structure, site, object, feature or open space that is not significant in the history, architecture, archaeology, engineering, or culture of this state or a community within this state, or of the United States.

Coping:

The top course of a masonry wall or parapet which projects beyond the wall surface to throw off the rain.

Corbel:

A small projection built out from a wall to support the eaves of a roof or some other feature.

Corinthian Order:

A classical order distinguished by the capitals, which are ornamented with stylized acanthus leaves.

Cornice:

In classical architecture, the upper projecting section of an entablature; projecting ornamental molding along the top of a building or wall. The term is loosely applied to any horizontal molding forming a main decorative feature such as a molding at the junction between a storefront and the upper wall.

Course:

A horizontal row of bricks, stones or other masonry units.

Cresting:

Ornamental ironwork used to embellish the ridge of a gable roof or the upper cornice of a mansard roof.

Cross Gable:

A gable which is set parallel to the ridge of the roof.

Cupola:

A small structure built on top of a roof or tower.

D**Deck:**

A roofless porch, usually at the rear of a building, popular in contemporary residential architecture.

Dentils:

Small, closely placed blocks set in a horizontal row used as an ornamental element, typically located where walls meet roofs or under porch roofs.

Doric Order:

The oldest of the classical orders, characterized by heavy fluted columns with no base, simple unadorned capitals supporting a frieze or vertically grooved tablets.

Dormer:

A vertical window projecting from the slope of a roof; usually provided with its own roof; used to light rooms in a half story.

Double-Hung Windows:

A window with two sashes, each movable up and down.

Downspout:

A pipe that carries water from the gutters to the ground, or to a cistern.

E

Eaves:

The projecting overhang at the lower edge of a roof.

Economic Hardship:

Also referred to as Financial Hardship, references the personal financial inability of an owner to make appropriate repairs to a historically designated building that meet the historic district guidelines and standards, through the use of historically appropriate materials and the like.

- Such requests are reviewed on a case by case bases. All avenues for utilizing the appropriate materials as part of the consideration/application for a hardship will be exhausted including the potential for an extended time frame for completion.
- Required evidence/documentation - Many elements must be provided with such an application that include but are not limited to:
 - o Personal banking information, all assets and, income personal or through business.
 - o Multiple estimates for undertaking the work utilizing historically appropriate materials and those utilizing an alternate material that comes as close as possible to meeting the other requirements of the guidelines and standards.
 - o Information and photos that illustrate what the issue being addressed is and what caused the issue. Information clarify if the proposed work will not only correct the issue but also its cause.
 - o Product information.

Elevation:

A scaled drawing which illustrates the view of any side of a building. Is also used loosely to describe the side of a building.

Ell:

A wing or extension of a building, often a rear addition, positioned at right angles to the principal mass.

Engaged Column or Pilaster:

A column that is in direct contact with a wall: at least half of the column projects beyond the surface of the wall to which it is engaged.

English Bond:

A method of laying brick wherein one course is laid with stretchers and the next with headers.

Entablature:

The horizontal part of a classical order, above the columns; consists of architrave, frieze, and cornice.

F**Façade:**

An exterior side of a building.

Fanlight:

A semicircular or fan-shaped window with a radiating glazing bar system usually found over an entrance door or in upper level gable ends.

Fascia:

A flat board used to cover the ends of roof rafters.

Fenestration:

The arrangement of windows and their exterior openings on a building.

Finial:

An ornament at the top of a spire, gable or pinnacle.

Fire Alarm System:

System designed to detect and annunciate the presence of fire or by-products of fire. Fire alarm systems include smoke alarms.

Flashing:

Thin metal used to prevent moisture infiltration at joints of roof planes and vertical surfaces.

Foundation:

The supporting portion of a structure below the first floor construction extending below grade.

Frieze:

The member between the architrave and cornice, also any plain or decorative band, or board, on the top of a wall immediately below the cornice.

G**Gable:**

A triangular wall segment at the end of a double pitched or gabled roof.

Galvanize:

To coat steel or iron with zinc.

Gambrel Roof:

A roof having a double slope on two sides of a building.

Gazebo:

A small summer structure with open walls and a roof and is typically found in a garden or rear yard.

German or Dutchlap Siding:

A type of clapboard siding characterized by overlapping boards where the upper part of each board has a concave curve.

H-I-J-K

Headers:

Bricks laid with their ends toward the face of a wall, or the structural supporting member located over door and window openings.

Hipped Roof:

A roof formed by four pitched roof surfaces meeting; where they meet at a point creating triangular surfaces it is often referred to as a Pyramid Roof.

Historic District:

An area, or group of areas not necessarily having contiguous boundaries, that contains 1 resource or a group of resources that are related by history, architecture, archaeology, engineering, or culture.

Integrity:

Integrity refers to the historic, character-defining physical features that convey a buildings, object, site or structure's significance as part of the district.

Ionic Order:

A classical order characterized by a capital embellished with opposing volutes.

Jerkin Head Roof:

A roof form in which the top of the gable is cut off by a secondary slope forming a hip. Sometimes referred to as a Hipped Gable.

Keystone:

The wedge-shaped stone, brick or wood feature located in the center of an arch.

L

Landmark:

A landmark essentially refers to a historic district that consists of one parcel that meets the Secretary of the Interior Criteria for Designation such as connection with persons of significant (local, state or national), connection with events of historical significance (local, state or national), architectural significance and/or archaeological significance. Such parcels may hold one structure or object, multiple structures or objects, or no structures or objects. Local Examples: Veterans Park, 6th Street Bridge, American Seating Complex, 7th Day Adventist Church, Oak Hill Cemetery, North & Trowbridge cobblestone streets, The Calder, and the Turner House.

Latticework:

Openwork produced by interlacing or crossing latch or thin strips of iron or wood; often used at the base of a porch (porch skirting).

Lean-To:

A small addition to a house with single pitched (shed) roof.

Light (Lite):

A pane of glass.

Lintel:

A horizontal structural member that supports a load over an opening.

Louver:

A small lantern or other opening, often with wood slats, used for ventilating attics or other spaces.

Lunette:

A small round or arched-top window in a vaulted or covered ceiling or roof.

M

Mansard Roof:

A roof that has two slopes on all four sides.

Masonry:

Work constructed using stone, brick, concrete, concrete blocks, tile, stucco, or similar materials.

Massing:

The three-dimensional form of a building that includes, width, depth and height.

Metal Standing Seam Roof:

A roof composed of overlapping sections of metal attached or crimped together in various raised seams.

Molding:

A continuous decorative band; serves as an ornamental device on both interior and exterior of a building.

Mortar:

A mixture of plaster, cement, or lime with affine aggregate and water used to for pointing and bonding bricks or stone.

Mullion:

A large vertical member separating window units and forming part of the window frame.

Muntin:

One of the thin strips of wood used for holding panes of glass within a window; also called sash bars, glazing bars or grids.

N-O-P-Q

Newel Post:

The post supporting the handrail at the top and bottom of a stairway.

Notice to Proceed:

Work within a historic district or landmark may be permitted through the issuance of a Notice to Proceed by the Historic Preservation Commission if any of the following conditions prevail and if the proposed work can be demonstrated by a finding of the Historic Preservation Commission to be necessary to substantially improve or correct any of the following conditions and all other avenues have been exhausted and failed:

- The resource constitutes a hazard to the safety of the public or to the structure's occupants.
- The resource is a deterrent to a major improvement project of substantial benefit to the community and the applicant proposing the work has obtained all necessary planning and zoning approvals, financing, and environmental clearances.
- Retaining the resource will cause undue financial hardship to the owner when a governmental action, an act of God, or other events beyond owner's control created the hardship, and all feasible alternatives to eliminate the financial hardship, which may include offering the resource for sale at its fair market value or moving the resource to a vacant site within the historic district, have been attempted and exhausted by the owner.
- Retaining the resource is not in the interest of the majority of the community.

Order:

A style of column and its entablature.

Open Space:

Undeveloped land, a naturally landscaped area, or a formal or man-made landscaped area that provides a connective link or a buffer between other resources.

Ordinary Maintenance:

Means keeping a resource unimpaired and in good condition through ongoing minor intervention, undertaken from time to time, in its exterior condition. Ordinary maintenance does not change the external appearance of the resource except through the elimination of the usual and expected effects of weathering. Ordinary maintenance does not constitute work for purposes of PA 169.

Oriel Window:

A bay window which is located above the ground floor level.

Palladian Window:

A window with three openings, the central one arched and wider than the flanked ones.

Pane:

A single piece of window glass.

Panel:

A sunken or raised portion of a wall, ceiling, mantel, storefront, bulkhead, or door with a frame-like border.

Parapet:

A low wall or protective railing often used around a balcony or along the edge of a roof.

Patio:

A usually paved and shaded area located flush with the grade and located in a rear or side yard.

Pediment:

A wide low-pitched gable surmounting the façade of a classical building; also used over windows, doors and niches.

Pergola:

An arbor or passageway with trellis roof on which plants would climb, typically located in gardens.

Pointing:

The final filling and finishing of mortar joints that have been left raw or raked out.

Porte-Cochere:

A large covered entrance through which a vehicle can drive.

Portico:

A major porch, usually with a pedimented roof supported by classical columns.

Portland Cement:

A hydraulic binder for concrete; made by burning a mixture of clay and limestone. Is not compatible with lime based mortars.

Quion:

Large stones, or rectangular pieces of wood or brick, used to decorate and accentuate the corners of a building.

R

Rake:

The slope of a gable, pediment, stair, string, etc.

Repair:

To restore a decayed or damaged resource to good or sound condition by any process. A repair that changes the external appearance of a resource constitutes work for purposes of PA 169.

Repointing:

Raking out deteriorated joints and filling them with a surface mortar to repair the joint.

Resource:

One or more publicly or privately owned historic or non-historic buildings, structures, sites, objects, features, or open spaces located within a historic district.

Retaining Wall:

A wall that bears against an earth backing.

Roof Ridge:

The horizontal line formed when two roof surfaces meet.

Rustication:

Rough-surfaced stonework.

S

Sash:

A frame for glass to close a window opening.

Segmental Arch:

An arch formed by the segment of a circle.

Shingle:

A wedge-shaped piece of wood as used in overlapping courses to cover a roof or an outside wall surface.

Sidelight:

One of a pair of narrow windows flanking a door. Sometimes there is only one sidelight.

Sill:

The framing member that forms the lower side of an opening, such as a window or door sill. Window sills are usually project past the exterior wall and slope down to shed water.

Smoke Alarm:

A single-station or multiple-station alarm responsive to smoke and not connected to a system. As used in this subdivision, "single-station alarm" means an assembly incorporating a detector, in the uni or obtained at the point of installation. "Multiple-station alarm" means 2 or more single-station alarms that a capable of interconnection such that actuation of 1 alarm causes all integrated separate audible alarms to operate.

Soffit:

The exposed underside of an arch, cornice, balcony, beam or eave.

Spall:

To split off from the surface, as when the face of a brick falls off.

Spandrel:

The triangular space between the shoulder of an arch and the triangular framework that surrounds it.

Stringcourse:

A continuous horizontal band of brick stone, or wood on the exterior wall of a building that is used for decorative purposes, or to break up a large expanse of wall surface. They are often place in a manner that visually divides floors.

Stucco:

An exterior wall covering consisting of a mixture of cement, sand, lime and water.

T

Technical In-Feasibility:

Occurs when a historic feature cannot be replaced in-kind as a result of a lack of available product. Example: A deteriorated asbestos tile roof or siding cannot be replaced in-kind as this material is no longer made.

Terra Cotta:

A fine-grained fired clay product used ornamentally on exterior of buildings, may be glazed or unglazed, molded or carved.

Tongue-and Groove:

A projecting rib along the edge of member fit into a corresponding groove in an adjacent member, often seen on porch floors.

Transom:

An opening over a door or window, usually for ventilation, and containing glazed or solid sash.

Trim:

The finish material on a building, such as a molding applied around doors, windows and at building corners.

Turret:

A small tower usually corbelled at the corner of a building.

U-V

Underpinning:

The system of supports, such as rough walls or piers, beneath the ground floor.

Valley:

The depressed angle formed at the meeting point of two roof slopes.

Volute: A spiraling scroll-like ornament.

W-X-Y-Z

Water Table:

A plain or molded ledge or projection, usually at the first-floor level where it meets the foundation that protects the foundation from rain running down the wall of the building.

Weather-strip:

A piece of wood, metal, or other material installed around window and door openings to prevent air infiltration and moisture penetration.

Work:

Means construction, addition, alteration, repair, moving, excavation, or demolition.

Wrought Iron:

Pig iron that is puddled and rolled or hammered into shape, never melted or cast.

